

plasma brush [®]

Operating instructions
PS2000 power supply



Thank you for buying a high-quality **Relyon Plasma** GmbH branded product.
To get the best from your machine, please read these instructions carefully.

i **Important!**
Read these instructions carefully before assembling, installing and starting up the machine!

Always follow the safety instructions! Failure to follow the safety instructions may result in accidents, serious injury and serious damage to the machine.

The PS2000 power supply may only be started up and operated by trained and qualified persons!

Train your staff! The operator/user is responsible for ensuring that personnel have fully understood the operation of the machine and the safety requirements.

© Copyright **Relyon Plasma** GmbH 2017.

All rights reserved. All rights reserved.

Text, images and graphics as well as their layout are protected by copyright and other protective laws. Unauthorised copying and distribution of this document and the utilisation and communication of its contents are strictly prohibited unless expressly authorised. Offenders will be held liable for the payment of damages. All rights reserved in the event of the grant of a patent, utility model or design.

Original operating
instructions

1	Safety	4
1.1	Residual risks.....	4
1.2	Information and obligations for the operator	5
1.3	Intended use	5
1.4	Impermissible operating conditions.....	5
2	Description of machine	6
2.1	Overview of the machine.....	6
2.2	Installation dimensions.....	6
2.3	Description and connections	7
2.4	Power connector pin assignment.....	8
2.5	Pin assignment of emergency stop plug.....	9
2.6	Pin assignment of CAN bus socket/plug (9-pin sub D socket/plug)	10
2.7	Scope of delivery.....	10
3	Technical data	11
3.1	Technical data.....	11
3.2	Permissible operating parameters	11
4	Transport/storage	12
5	Unpacking and installation	12
5.1	Unpacking	12
5.2	Installation requirements.....	12
5.2.1	Installing and starting up one single PS2000	12
5.2.2	Installing and starting up several PS2000s running in parallel.....	14
6	Operation	15
6.1	Controls / displays.....	15
6.2	Switching on and operating the machine	15
6.2.1	Switching on and operating machine without bus communication	15
6.2.2	Switching on and operating machine with bus communication	16
6.3	Switching off the machine	22
6.4	Error acknowledgement	22
7	Taking out of service	23
8	Maintenance and cleaning	24
8.1	Maintenance.....	24
8.2	Cleaning	24
9	Troubleshooting	25
9.1	Overview of faults / errors	25
9.2	Customer service	25
10	Environment	26
10.1	Disposal	26
11	Conformity / standards	26
11.1	CE	26
11.2	Product standards	26

1 Safety

The PS2000 power supply was designed in accordance with the relevant international standards. However, as with any technical product, hazards may arise if the system is not used properly or is used for purposes other than its intended use.

Working with the PS2000 power supply can be dangerous and may result in serious or fatal injury. It is therefore essential to protect yourself and others.

In addition to the safety instructions in this document, you must also comply with general safety standards.



Caution - Danger!

When working with the machine, please note and observe the safety instructions and requirements in these operating instructions because non-compliance may result in serious or fatal injury.

1.1 Residual risks

This machine has been manufactured in accordance with the current state of the art. However, it is impossible to eliminate residual risks.

Always adhere to the following safety instructions:



Caution – electrical voltage!

- Danger from high voltage
 - Never reach into the plasma beam of the connected plasma generator.
 - During operation, never touch the workpiece in contact with the plasma beam or the fixture that holds the workpiece.
 - Never touch the connected plasma generator when the system is in operation.
 - Never direct the plasma beam at people or animals.
 - Earth the plasma generator by fitting in a holding fixture.
- Danger: 230 V. If damage is visible on the electrical connection, mains cable or machine:
 - Do not start up the machine.
 - Replace the damaged parts or have them repaired by a qualified person.



Caution – Health hazard!

The machine operates at a high frequency (40 - 65 kHz in plasma generator).

- As a precaution, persons with a pacemaker or hearing aid should observe the following:
 - Do not use the PS2000 power supply near the pacemaker or hearing aid.
 - Seek medical advice before working near the system.
- In hospitals and similar facilities, it is possible that the operation of the system may impair the function of electrical medical equipment, computer equipment, or other equipment (such as ECG systems or PCs).
 - Make sure that the operator of such equipment or systems is aware of this possibility before starting up the machine.



Tripping hazard!

Lay connection cables such that they do not present a tripping hazard.



Attention – damage to machine!

The machine may overheat. Do not cover the ventilation slots.

1.2 Information and obligations for the operator

- The system may emit interference.
 - The system has been tested in accordance with EMC legislation.
 - The operator must verify and assure electromagnetic compatibility with other electrical and electronic equipment in the immediate vicinity of the system.
- Ensure that:
 - Operating personnel have read and understood these operating instructions.
 - Anyone working near the machine is made aware of the dangers and is provided with the necessary protective equipment.
 - Installations and repairs are only carried out by qualified persons.
- In particular, make operating personnel aware of the safety instructions in this document.
- Always keep the system in fully functional condition.
- Any modifications made to the machine will invalidate the operating licence and the warranty. Exception: Such modifications are expressly authorised by the manufacturer.

1.3 Intended use

The PS2000 power supply is only intended for operation of a plasma generator from **Relyon Plasma GmbH**.

The machine is only intended for plasma surface treatment in combination with a suitable plasma generator.

Under no circumstances may the machine be used by non-trained persons.

The machine is intended for installation in a control cabinet.

1.4 Impermissible operating conditions

The machine must not be operated under the following conditions:

- In explosive (EX) zones
- In areas with severe build-up of dust
- In environments where the humidity is too high (see technical data, page 11)
- At altitudes of more than 2,000 m above sea level
- Where there are strong vibrations

2 Description of machine

2.1 Overview of the machine

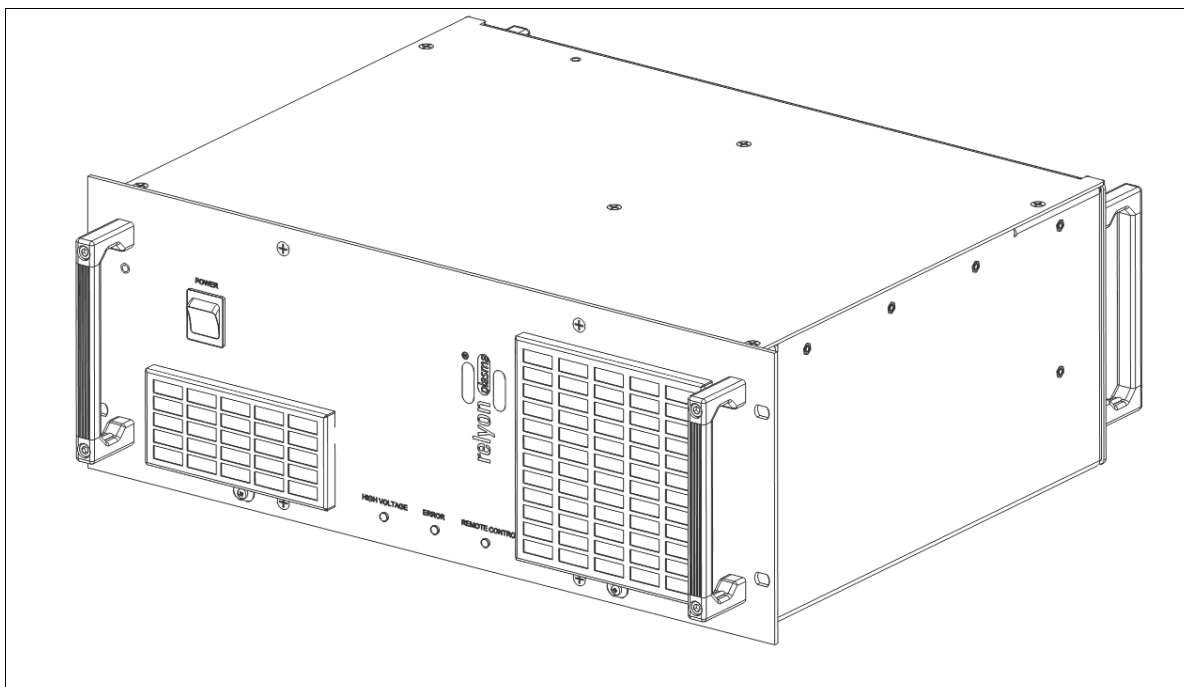

Component

PS2000 high-voltage power supply

2.2 Installation dimensions

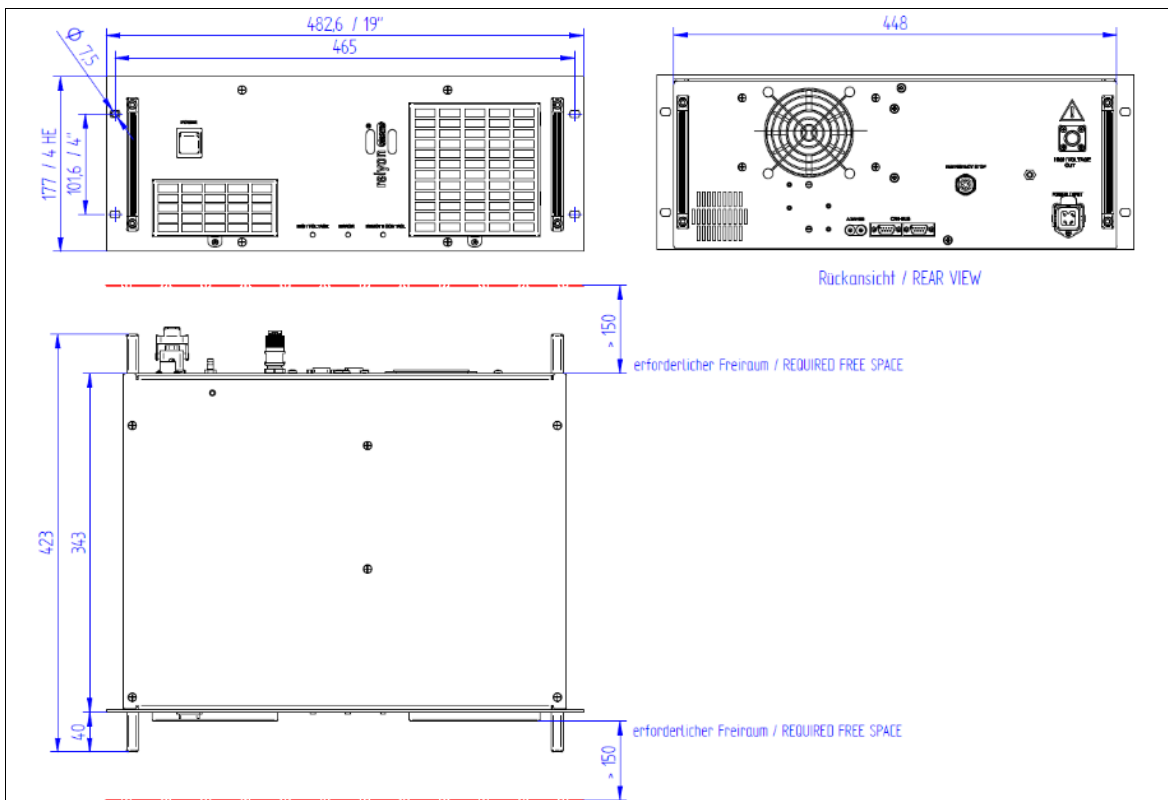

2.3 Description and connections

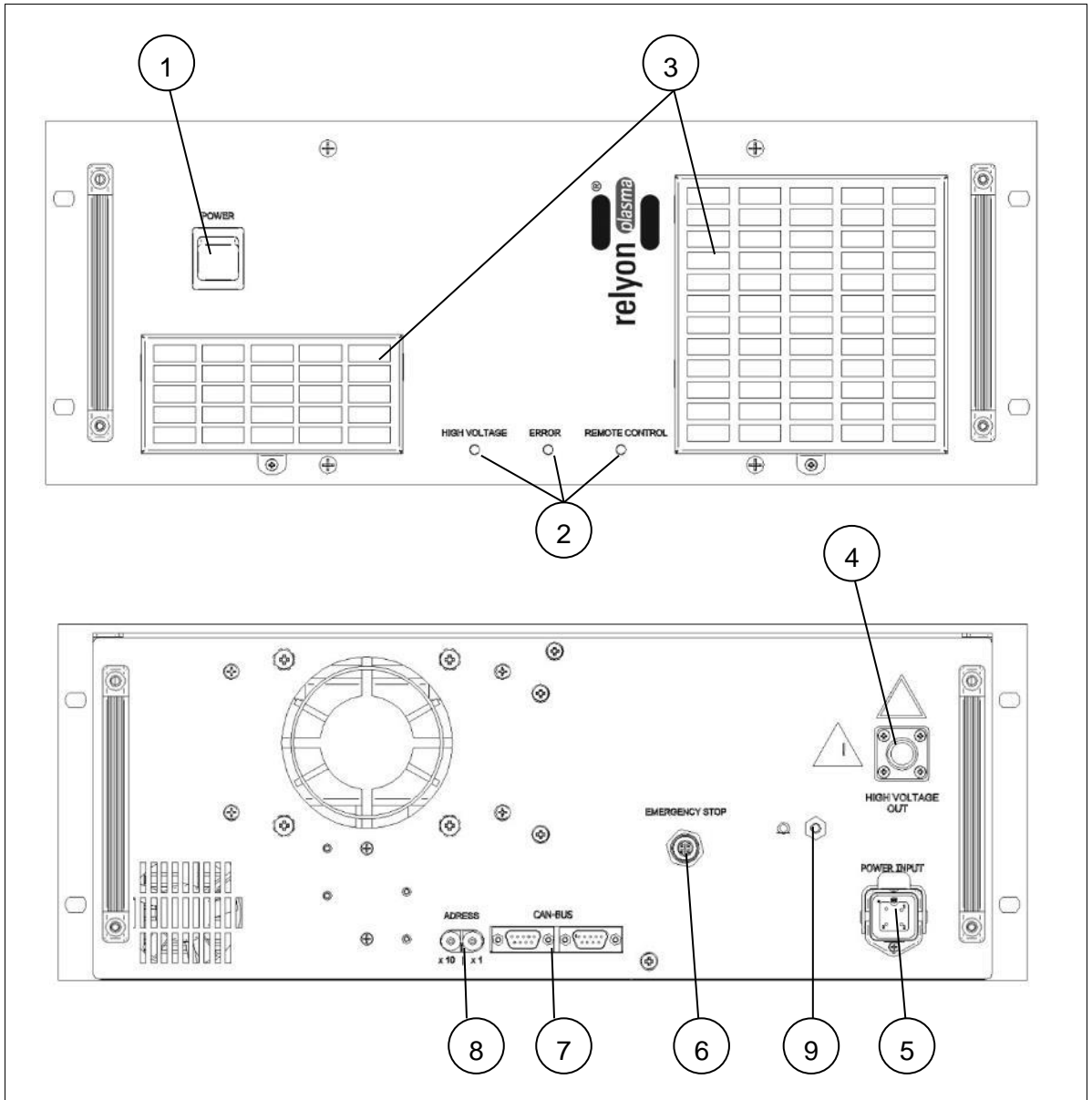
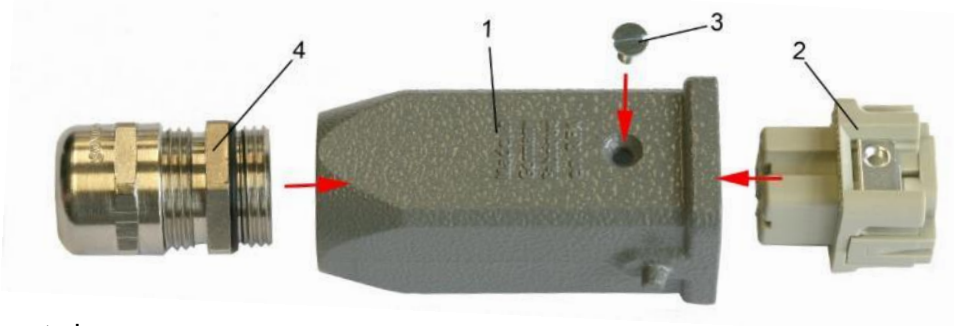

Fig.: Diagram of front (top) and rear (bottom) of the PS2000

No.	Component
1	Master switch I/O
2	Status LED
3	Ventilation grille with dust filter (class G2 coarse dust filter)
4	GES HB 30 PTFE high-voltage socket for connecting an HVC high-voltage cable
5	230 V AC, 50 Hz power connector (for cable type: H05V 3G1.5 CE (3 x 1.5mm ²)) Harting HAN 3
6	Harting HAN M12 emergency stop plug connector
7	Communication (CAN bus) interface (sub D 9-pin) X21, X22
8	Address selector switch
9	Earthing connection

2.4 Power connector pin assignment

The power connector comprises the following components:



- 1: Support sleeve
- 2: Panel jack
- 3: Retaining bolt (earthing function)
- 4: PG cable screw connection

Use a H05V 3G1.5 CE (3 x 1.5 mm²) cable to connect the power plug.

The panel jack pin assignment:

PIN 1: L1
PIN 2: N
PIN 3: not connected
PE PIN: PE



Fig. Pin assignment of mains voltage socket (left) and view of connection side (right)

Only the electricians responsible may connect the wires to the socket (plug assembly)!

2.5 Pin assignment of emergency stop plug

The emergency stop plug supplied consists of 4 individual parts which have to be plugged/screwed together as shown.



Pin assignment of the emergency stop plug:

- PIN 1: +24 V output**
- PIN 2: 0 V / GND output**
- PIN 3: +24 V input (+/- 10%)**
- PIN 4: 0 V input**



Fig. Pin assignment of emergency stop plug (left) and view of self-tapping cable guide (right)

Principle of connection to emergency stop circuit

Internal emergency stop circuit

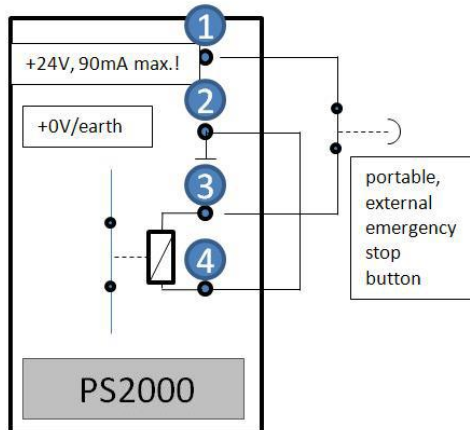

Integration in external emergency stop circuit

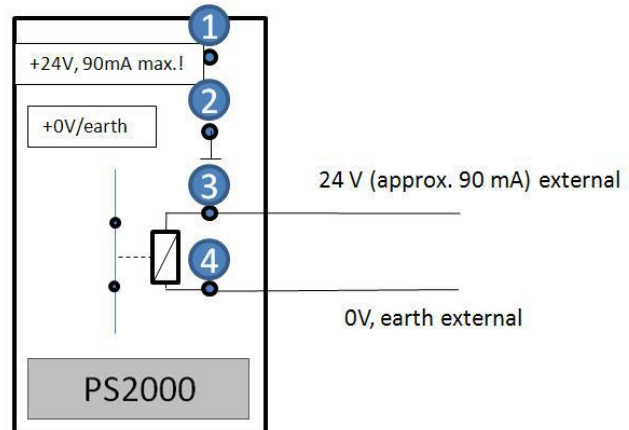

24 V

If using an external voltage (integration in external emergency stop circuit), ensure that the voltage is 24V DC (+/- 10%) (load: approx. 90 mA).

The output (pin 1-2) of the PS2000 must not be loaded with more than 90 mA under any circumstances.

2.6 Pin assignment of CAN bus socket/plug (9-pin sub D socket/plug)

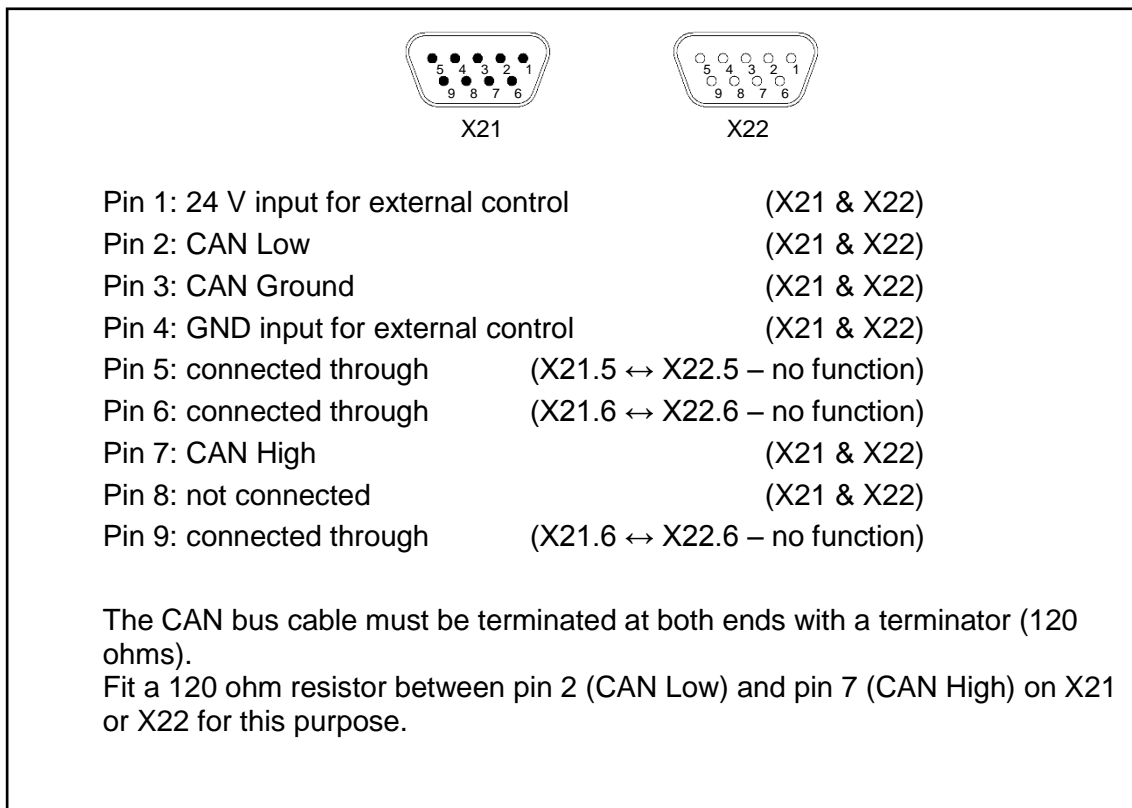

Fig.: Pin assignment of sub D socket/plug (left) and diagram of both interfaces (right).

2.7 Scope of delivery

The scope of delivery includes the following components:

- PS2000 power supply.
- Power connector for electrical connection of power supply (not mounted).
- Round plug connector for connecting and integrating the PS2000 in internal or external emergency stop circuit (Harting HAN M12).
- Operating instructions.

3 Technical data

3.1 Technical data

Description	Value
Electrical data	
Electrical connection	220 V – 240 V AC / 50-60 Hz / max. 6 A
Mains fuse	F1 = 6.3 A / 230 V AC / time lag
Power consumption	≤ 1200 VA
Power loss	Pmax: 450 W
Protection	IP20 acc. to EN 60529
Protection class	Class I acc. to IEC 61140
Operating voltage of plasma generator	<ul style="list-style-type: none">• up to 20 kV U_{peak} (max. voltage for ignition (briefly))• up to 2 kV RMS (average operating voltage)
Internal F1, F2 fuses	6.3 A / 500 V AC /time lag, SIBA type 189140.6.3
Dimensions	
Weight	18.0 kg; 39.7 lbs
Dimensions	483 x 177 x 430 mm (corresponds to 4 HU); 19" x 6.97" x 16.93" (W x H x D)
Operating conditions	
Air humidity	< 80% rel. (non-condensing)
Temperature	0– 40°C; 32 – 104°F
Storage conditions	
Air humidity	< 80% rel. (non-condensing)
Temperature	0 – 60°C; 32 – 140°F
Emissions	
<ul style="list-style-type: none">• Sound level	< 60 dB(A) at 1 metre away
<ul style="list-style-type: none">• Waste heat	Pmax: 450 W

3.2 Permissible operating parameters

All system components of the plasma generator must be earthed.

During operation, the specified limits must be observed:

Description	Value
Plasma on	Before activating the high voltage for plasma generation, the gas supply to the plasma generator must be switched on for at least 2 seconds.

4 Transport/storage

- Store the PS2000 power supply in a dry place. This will prevent the electrical contacts from corroding.
- Protect the PS2000 power supply from dirt and foreign bodies.

5 Unpacking and installation



Caution – electrical voltage!

Danger: 230 V and high voltage.

- Only electricians may connect the PS2000 power supply to the mains voltage supply and connect the plasma generator and HVC cable extension to the PS2000 power supply.

5.1 Unpacking

- Carefully open the PS2000 packaging. Note the information about directions provided on the packaging.
- Take the PS2000 out of the packaging.
- After removing, check in particular the rear mains plug (see page 7, Part #6) to ensure that the O-ring is positioned correctly in the socket.

5.2 Installation requirements

Before installing the machine, the following points must be met:

- The machine must be fully intact.
- If the PS2000 communicates with a superordinate control unit, the pins for the CAN bus connection must be assigned following the requirements in these operating instructions (see page 10).
- If installing as a permanent installation or in a building, a suitable switch or circuit breaker that satisfies national safety requirements (in Germany: VDE 0100) must be fitted as an upstream all-pole cut-off device that will disconnect the machine from the power supply. This cut-off device should be fitted near the machine and must be easily accessible to the user. The switch must also be labelled as the cut-off device for the machine.

5.2.1 Installing and starting up one single PS2000

The PS2000 can be mounted horizontally or vertically. Ensure a sufficient distance between the nearest housing wall and the ventilation slots (>150 mm).

To install the machine, perform the following steps in the specified order:

1. Mount the machine in a 19" control cabinet intended for this purpose. Only use the support rails on which the PS2000 is mounted to distribute the weight.
 - Use fixing bolts to secure the PS2000 in the bracket. Use the four slots in the front plate (#11) provided for this purpose.
 - Please ensure sufficient space between the control cabinet wall and front/rear (for electrical connections, dissipation of heat). This must not be any less than 150 mm.

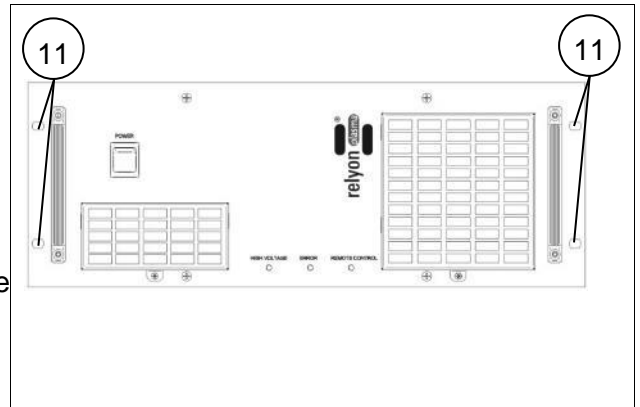

2. Establish high-voltage connection between HVC cable extension and connection socket (#5) on the PS2000.
3. Mount an appropriate plasma generator. Make sure that the screw connection is hand tight.

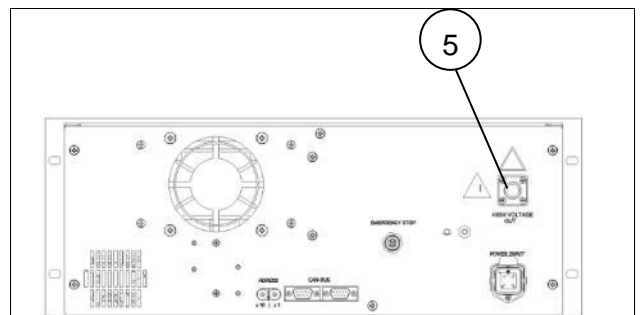

4. Also earth the PS2000 at the earthing connection (#10) (M5 thread)
5. Connect PS2000 with the emergency stop circuit using the socket (#7).
6. Establish power supply to PS2000 (#6).
 - 230 V / 50 Hz
 - Cable type: H05V 3x1.5 mm²
 - Please ensure a safe electrical connection (especially PE conductor).

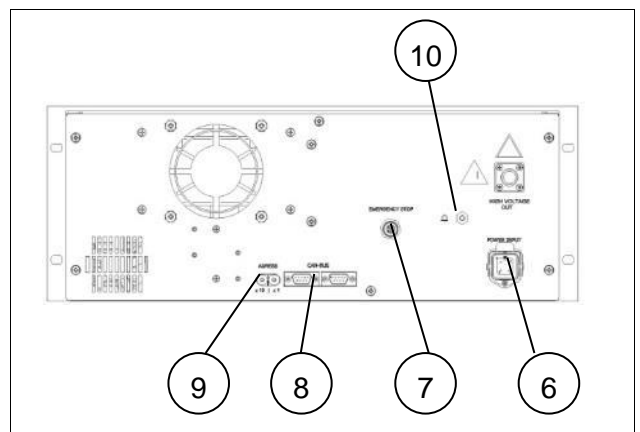

7. A CAN bus interface should be fitted with a terminator for individual PS2000 operation (see page 10)

✓ The machine is installed.

5.2.2 Installing and starting up several PS2000s running in parallel

To install and start up several PS2000s which are controlled in parallel by one control unit, please proceed as follows:

1. Perform steps 1-6 for starting up an individual PS2000
2. For each PS2000, set a separate machine address on the rotary switch (#9).
3. Connect all PS2000s in series with the communication bus (#8).
Since there is a bus signal on both ports (X21&X22), you can connect the various PS2000s with one another. Make sure that a suitable cable is used for the connection between the PS2000s.

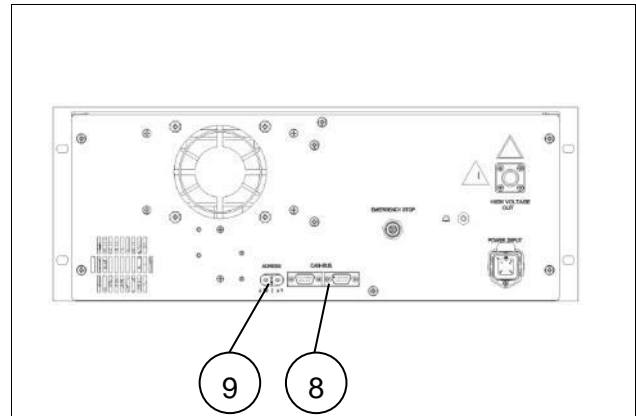

Terminator

Please ensure that the CAN bus cable is terminated at both ends by a terminator (120 ohms) (resistor configuration / pin assignment: see page 10).

- ✓ The machines are installed.

6 Operation

6.1 Controls / displays



Caution – electrical voltage!

Danger of electric shock.

- Never reach into the area around the connected plasma generator while it is running or if it has shut down (e.g. to check why the plasma generator has shut down).

The PS2000 has LEDs indicating the current status.

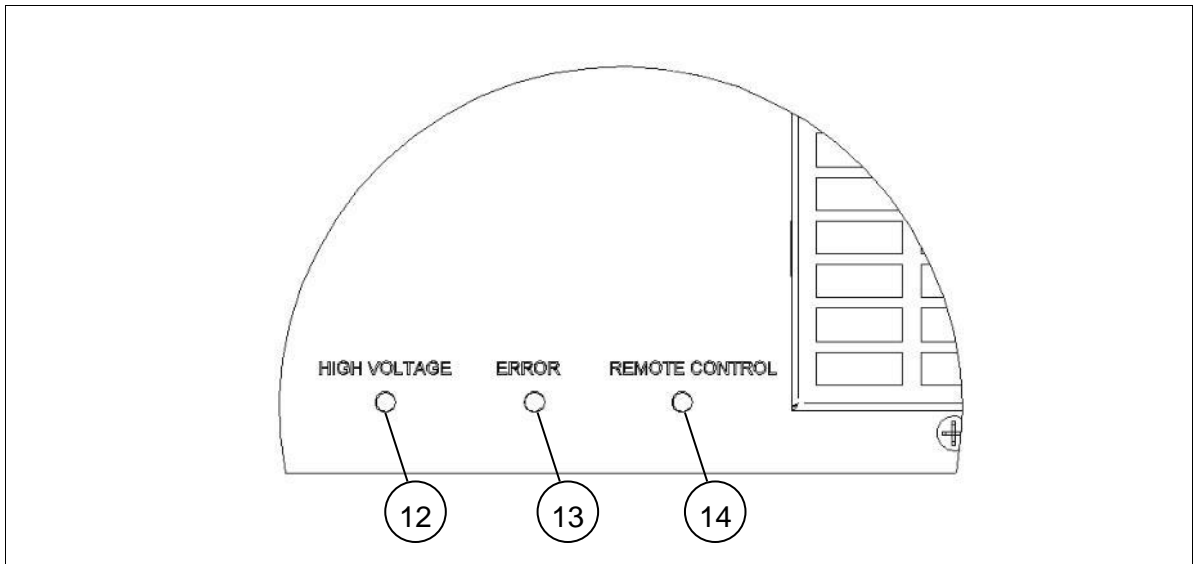

No.	Display	Function
12	High Voltage	There is high voltage at the output of the connection socket (#5).
13	Error	There is an error present. It can be read off via the CAN bus. PS2000 is not ready. The error must be acknowledged before the machine can be operated again.
14	Remote Control	Communication with superordinate control unit possible. The current source cannot be switched on in this operating mode via the 24 V start signal.

6.2 Switching on and operating the machine

6.2.1 Switching on and operating machine without bus communication



Attention – damage to machine!

The machine must only be operated with the plasma generator connected.

The plasma generator may be damaged if it is operated with no gas or too little gas.

- Never switch on the high voltage before sufficient gas is flowing through the plasma generator! Please comply with the information in the operating instructions for the plasma generator.

To switch on the PS2000 without bus communication, perform the following steps in the order given:

1. Switch machine on using master switch (#1).
 ➔ The master switch lights up green.
 2. Ensure that a plasma generator is correctly connected to the PS2000 and that sufficient gas is flowing through the plasma generator.
 3. Connect 24 V at pin 1 to the plug X21 or X22 (GND is pin 4).
- ✓ The machine is switched on.

If the machine is operated without bus communication, the electric parameters for plasma generation cannot be changed. When supplied, the PS2000 is operated with the following parameters: Frequency: 54 kHz, nominal output: 100%

6.2.2 Switching on and operating machine with bus communication

The PS2000 can be operated externally in two ways:

- a. Via the "plasma control" software: This software is available from **Relyon Plasma GmbH** and is used to control an individual PS2000.
 This software and the appropriate CAN/USB converter can be used to change and log operating parameters. Information about operating the PS2000 can be found in a separate data sheet supplied with the software.
- b. Via a control device produced by the customer. The CANopen protocol is based on the CIA301 specification. The object directory and linked information are described below.

6.2.2.1 CANopen object directory for control device produced by the customer

<i>Index hex</i>	<i>Sub-Index hex</i>	<i>Name (reference)</i>	<i>Attribute</i>	<i>Mapable</i>	<i>Object type</i>	<i>Data type</i>	<i>Default value</i>	<i>Comment</i>
1000	00	Device type	ro	n	VAR	UNSIGNED32	0x00000000	
1001	00	Error register	ro	y	VAR	UNSIGNED8	0x00	See "Error message"
1003		Pre-defined error field			ARRAY	UNSIGNED32		
	00	Number of errors	rw	n		UNSIGNED8	00h	
	01	Standard error field	ro	n		UNSIGNED32	0000 0000h	
	02	Standard error field	ro	n		UNSIGNED32	0000 0000h	
	03	Standard error field	ro	n		UNSIGNED32	0000 0000h	
	04	Standard error field	ro	n		UNSIGNED32	0000 0000h	
1005	00	COB-ID SYNC message	rw	n	VAR	UNSIGNED32	0000 0080h	
1008	00	Manufacturer device name	ro	n	VAR	VISIBLE_STRING	"PS2000"	
1009	00	Manufacturer hardware version	ro	n	VAR	VISIBLE_STRING	hardware version string,	
100A	00	Manufacturer software version	ro	n	VAR	VISIBLE_STRING	software version string, e.g. "V01.00"	
100C	00	Guard time	rw	n	VAR	UNSIGNED16	0000h	0..32000 [ms]
100D	00	Life time factor	rw	n	VAR	UNSIGNED8	00h	0..255 [factor] for guard time

Index hex	Sub-Index hex	Name (reference)	Attribute	Mapable	Object type	Data type	Default value	Comment
1010		Store parameters			ARRAY	UNSIGNED32		
	00	Highest sub-index supported	ro	n		UNSIGNED8	04 _h	
	01	Save all parameters	rw	n		UNSIGNED32	0000 0001 _h	Ascii "save" Complete object directory (incl. 2040-2043) is saved
	02	Save communication parameters	rw	n		UNSIGNED32	0000 0000 _h	"save" not supported
	03	Save application parameters	rw	n		UNSIGNED32	0000 0000 _h	"save" not supported
	04	Save manufacturer defined parameters	rw	n		UNSIGNED32	0000 0001 _h	"Burn in" set of parameters - Only objects 2040-2043 are saved
1011		Restore parameters			ARRAY	UNSIGNED32		
	00	Highest sub-index supported	ro	n		UNSIGNED8	00 _h	
	01	Restore all parameters	rw	n		UNSIGNED32	0000 0001 _h	Ascii "load" Complete object directory (NOT INCLUDING 2040-2043) is deleted.
	02	Restore communication parameters	rw	n		UNSIGNED32	0000 0000 _h	"load" not supported
	03	Restore application parameters	rw	n		UNSIGNED32	0000 0000 _h	"load" not supported
	04	Restore manufacturer defined parameters	rw	n		UNSIGNED32	0000 0001 _h	"Burn in" set of parameters is reset to factory settings
1014	00	COB-ID emergency message	rw	n	VAR	UNSIGNED32	80 _h + node ID	
1016		Consumer heartbeat time			ARRAY			
	00	Highest sub-index supported	ro	n		UNSIGNED8	03 _h	
	01	Consumer heartbeat time	rw	n		UNSIGNED32	0000 0000 _h	0..32000[ms]
	02	Consumer heartbeat time	rw	n		UNSIGNED32	0000 0000 _h	0..32000[ms]
	03	Consumer heartbeat time	rw	n		UNSIGNED32	0000 0000 _h	0..32000[ms]
1017	00	Producer heartbeat time	rw	n	VAR	UNSIGNED16	0000 _h	
1018		Identity object			RECORD	IDENTITY		
	00	Highest sub-index supported	ro	n		UNSIGNED8	04 _h	

Index hex	Sub-Index hex	Name (reference)	Attribute	Mapable	Object type	Data type	Default value	Comment
	01	Vendor ID	ro	n		UNSIGNED32	0000 0000 _h (Bosch Rexroth AG Pneumatics – ship engineering)	
	02	Product code	ro	n		UNSIGNED32	0000 0000 _h	
	03	Revision number	ro	n		UNSIGNED32	0000 0000 _h	
	04	Serial number	ro	n		UNSIGNED32	FFFF FFFF _h	
1200		SDO server 1 parameter			RECORD	SDO_PARAMETER		
	00	Highest sub-index supported	ro	n		UNSIGNED8	02 _h	
	01	COB ID client -> server (rx)	ro	n		UNSIGNED32	0000 0600 _h + Node ID	
	02	COB ID server -> client (tx)	ro	n		UNSIGNED32	0000 0580 _h + Node ID	
1400		RPDO 1 comm. parameter			RECORD	PDO_COMMUNICATION_PARAMETER		
	00	Highest sub-index supported	ro	n		UNSIGNED8	02 _h	
	01	COB ID used by RPDO	rw	n		UNSIGNED32	0000 0200 _h + Node ID	
	02	Transmission type	rw	n		UNSIGNED8	FF _h	“FF” asynchronous; “1” synchronous; See CIA301
1600		RPDO 1 mapping parameter			RECORD	PDO_MAPPING		
	00	Number of mapped application objects in RPDO	ro	n		UNSIGNED8	Number of mapped objects (digital outputs)	5
	01	1 st application object	ro	n		UNSIGNED32	2030 00 08	
	02	2 nd application object	ro	n		UNSIGNED32	2040 00 08	
	03	3 rd application object	ro	n		UNSIGNED32	2041 00 10	
	04	4 th application object	ro	n		UNSIGNED32	2042 00 10	
	05	5 th application object	ro	n		UNSIGNED32	2043 00 10	
1800		TPDO 1 comm. parameter			RECORD	PDO_COMMUNICATION_PARAMETER		
	00	Highest sub-index supported	ro	n		UNSIGNED8	05 _h	
	01	COB ID used by TPDO	rw	n		UNSIGNED32	0000 0180 _h + Node ID	
	02	Transmission type	rw	n		UNSIGNED8	FF _h	
	03	Inhibit time	rw	n		UNSIGNED16	0000 _h	See CIA301 0..32000 [ms]
	05	Event timer	rw	n		UNSIGNED16	0000 _h	See CIA301 0..32000 [ms]

Index hex	Sub-Index hex	Name (reference)	Attribute	Mapable	Object type	Data type	Default value	Comment
1A00		TPDO 1 mapping parameter			RECORD	PDO_MAPPING		
	00	Number of mapped application objects in TPDO	ro	n		UNSIGNED8	Number of mapped objects (digital inputs)	5
	01	1 st application object	ro	n		UNSIGNED32	2010 00 08	
	02	2 nd application object	ro	n		UNSIGNED32	2020 00 08	
	03	3 rd application object	ro	n		UNSIGNED32	2021 00 10	
	04	4 th application object	ro	n		UNSIGNED32	2022 00 10	
	05	5 th application object	ro	n		UNSIGNED32	2023 00 10	
1F51		Program control			Array	UNSIGNED8		
	00	Highest sub-index supported	ro	n		UNSIGNED8	1	
	01	Program 1	rw	n		UNSIGNED8		Internal use - do not change!

2000	00	Error status	rw	n	VAR	UNSIGNED8		0 Rw: Delete error statuses, see "Error message" RPDO2; Byte1
2010	00	Status code	ro	j	VAR	UNSIGNED8		See "Status code"; TPDO1; Byte1
2020	00	Power actual	ro	j	VAR	UNSIGNED16		TPDO1; Byte3,4
2021	00	Frequency actual	ro	j	VAR	UNSIGNED8		TPDO1; Byte2
2022	00	Voltage RMS actual	ro	j	VAR	UNSIGNED16		TPDO1; Byte5,6
2023	00	Current RMS actual	ro	j	VAR	UNSIGNED16		TPDO1; Byte7,8
2030	00	High Voltage	rw	j	VAR	UNSIGNED8	Write: 0/1 Read: Corresponding status code 0x2010 (PlasmaOk)	RPDO1; Byte1
2040	00	Power set	rw	j	VAR	UNSIGNED8		0..100; RPDO1; Byte2
2041	00	Frequency set	rw	j	VAR	UNSIGNED16		RPDO1; Byte3,4
2042	00	Voltage threshold	rw	j	VAR	UNSIGNED16		Internal error threshold - do not change! RPDO1; Byte5,6
2043	00	Current threshold	rw	j	VAR	UNSIGNED16		Internal error threshold - do not change! RPDO1; Byte 7,8
2050		Temperature			Array			
	00	Highest sub-index supported	ro	n		UNSIGNED8	5	
	01	Temperature 1	ro	n		UNSIGNED8		TPDO2; Byte3

Index hex	Sub-Index hex	Name (reference)	Attribute	Mappable	Object type	Data type	Default value	Comment
	02	Temperature 2	ro	n		UNSIGNED8		TPDO2; Byte4
	03	Temperature 3	ro	n		UNSIGNED8		TPDO2; Byte5
	04	Temperature 4	ro	n		UNSIGNED8		TPDO2; Byte6
	05	Temperature 5	ro	n		UNSIGNED8		
2060	00	Power-On time	ro	n	VAR	UNSIGNED16		TPDO02; Byte1,2
2100	00	Internal use	wo	n	VAR	UNSIGNED32		Do not change!
2110	00	Internal use	ro	n	VAR	UNSIGNED16		

- Please always ensure that the operating parameters of the PS2000 are within the stated range of values:

Description	Adjustable value	Default values ("Burn in" set of parameters)
Frequency set [Hz]	40000-65000 (step width 200 Hz)	54000 Hz
Power set [%]	70-100 (step width 1)	100%
Voltage threshold [V]	Internal error threshold - do not change!	500 V
Current threshold [mA]	Internal error threshold - do not change!	100 mA

- Standard baud rate: 500 kbit/s. Baud rate can be changed via LSS protocol (defined using CIA305). Supported baud rates: 1 Mbit/s, 500 kbit/s, 250 kbit/s, 125 kbit/s
- "Remote control" LED: To visualise communication via an illuminated "Remote control" LED, the "Operational" status must be set once in the CANopen State Machine (network management command: 0x00 0x01 + corresponding node number of the PS2000 (reset to "preoperational": 0x00 0x80)).
- The communication status should be continuously monitored via the "Guard" or "Heartbeat" telegram! If there is no communication, the PS2000 must switch off the high voltage!



Attention – Safety!

We would highly recommend querying and monitoring the "Guard" or "Heartbeat" telegram so that the PS2000 can still be switched in the event of e.g. loss of communication with the superordinate control unit.



Attention – damage to machine!

Please only change the approved parameters! If incorrectly actuated, the PS2000 may develop serious faults or be destroyed.

6.2.2.2 Error messages

Unexpected events are transmitted in the following form:

ID: 80h+NodeID data: 0x00 0xFF 0x81 0xyy 0x00 0x00 0x00 0x00

yy: Error code according to error status 1..16h

yy: 0x50 → Data received via RPDO is not within the valid range - valid parameters were adopted and invalid ones ignored.

The error codes have the following meanings:

Error address	Error message
01h	Error: switching circuit central
02h	Temp.: switching circuit central
03h	Error: auxiliary voltage 1
04h	Intermediate circuit voltage
05h	Error: controller
06h	Error: auxiliary voltage 2
07h	Is not used
08h	Temperature of switching circuit central/PCB too high
09h	Communication with controller interrupted
10h	Error PFC
11h	Emergency stop actuated
12h	Is not used
13h	Output voltage too low
14h	Overvoltage
15h	Error: fan
16h	Is not used

6.2.2.3 Status code

Status code	Bit	Description
01h	0	High voltage switched on
02h	1	Plasma ok
04h	2	Power supply ready
08h	3	Error

6.2.2.4 "Burn in" set of parameters

To change the "Burn in" set of parameters, the following is undertaken with the current parameters (2040 Power set, 2041 Frequency set, 2042 Voltage threshold, 2043 Current threshold):

- 1010 sub-index 01: all parameters are transferred and written
- 1010 sub-index 04: only the "Burn in" parameters are transferred and written.



Attention – damage to machine!

Do not change the threshold values (voltage / current threshold) for the "Burn in" parameters! If incorrectly actuated, the PS2000 may display serious faults or be destroyed.

6.3 Switching off the machine

To switch off, perform the following steps in the order given:

1. Switch off plasma generation.
 2. Switch machine off using master switch.
- ✓ The machine is switched off.

6.4 Error acknowledgement

When the PS2000 reports an error (error LED lights up), the reason for the error message can be read via the CAN bus interface (error code).

Please remedy the cause of the error. Please contact the customer service if anything is unclear.

Once the cause of the error has been remedied, the error message can be acknowledged. There are two ways of doing this:

- a) Operation without bus communication: Switch off the PS2000 at the master switch and switch on again approximately 5 seconds later. The error is acknowledged.
- b) Operation with bus communication: Acknowledge the error using the control software provided or by acknowledging the error status: Enter "0x00" in the object index 0x2000/00 (falling edge).

7 Taking out of service



Caution – electrical voltage!

Danger: 230 V and high voltage.

- Only electricians may disconnect the power supply, plasma generator or HVC cable extension from the PS2000 power supply.



Caution – electrical voltage!

Danger due to high voltage at output.

- After switching off the high voltage / supply voltage, there may still be high voltage on the output for up to 1 second. Please be aware of this whenever working on the PS2000, high-voltage cable and plasma generator.

To take the machine out of service, perform in the following steps in the order given:

1. Switch machine off using master switch (#1).
2. Disconnect the PS2000 from the mains voltage supply: Disconnect the power connector (#6).
3. Remove the HVC cable extension and the plasma generator.
4. Remove the PS2000 power supply.

- ✓ The machine is out of service.

8 Maintenance and cleaning

8.1 Maintenance



Caution – High voltage! Danger of death!

High voltage is produced in the PS2000 power supply's power pack. This voltage is still present after the machine is switched off.

- It is forbidden to open the machine.
- Whenever undertaking maintenance or repair work on the PS2000 or its connected components, always disconnect the power supply to the PS2000.



Attention – damage to machine!

Opening the machine may cause it to be damaged.

- It is forbidden to open the machine.

With the exception of the dust filters used, the machine requires no maintenance.

Replace the filter mat at least every 5000 operating hours. If working in environments with high levels of dust, they may have to be replaced sooner. You can source the filter mats needed as spare parts from

Relyon Plasma GmbH.

To change the dust filters, proceed as follows:

1. Disconnect the power supply to the PS2000.
2. Open the ventilation grille by loosening the screw stated (#15)
3. Take out the old dust filter and insert a new one (class G2 coarse dust filter).
4. Screw the ventilation grille with the new filter to the PS2000.

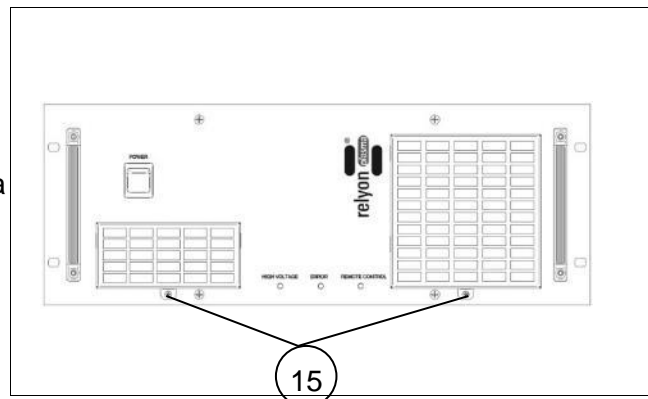

8.2 Cleaning

Only clean the outside of the PS2000 power supply.

- The PS2000 power supply must be switched off and disconnected from the mains voltage supply.
- Only dry clean the PS2000 power supply.

9 Troubleshooting

9.1 Overview of faults / errors

Fault / error	Cause	Rectification
Master switch (#1) does not light up	Fuse defective.	Fuse in machine must be changed. Contact customer service.
	Power connector incorrectly connected.	Check the mains unit connection.
	No / incorrect voltage supply.	Check the mains voltage supply.
"Error" LED (#13) lit up	There is an error, the machine is not ready.	Read out (CAN bus), rectify and acknowledge the error. Without CAN bus communication, switch the PS2000 off, wait 5 seconds then switch it back on.
		De-energise the machine. Switch on again.
		Problem cannot be fixed: Contact customer service.
Even though the 24 V start signal is present, plasma is not being ignited at the plasma generator.	"Remote control" LED (#14) lit up.	The machine is controlled via the CAN bus. Operation via the 24 V start signal is not possible in this operating mode.
	"Error" LED lit up (#13)	See error message for "LED Error" lit up.
		Check whether there is a sufficient flow of gas (35 to 80 l/min) through the connected plasma generator.
		Check that the HV cable and gas supply pipe are correctly connected, and are undamaged and not buckled.
Parasitic discharge (discharge at undesired points, e.g. at plasma generator cable connector)	Machine or high-voltage cable damaged	Take the machine out of operation and contact customer service.
Flashover (e.g. on machine parts)	Faulty earth connection	Check that all earth connections have been established correctly.

9.2 Customer service

If the machine is not working properly, return it to **Relyon Plasma GmbH** to be checked. You will find the customer service address at the end of the operating instructions.

10 Environment

10.1 Disposal



Be mindful of the environment.

Used electrical and electronic equipment must not be disposed of along with normal waste.

- The machine contains valuable materials that can be recycled. Take the machine to a suitable collection point.

11 Conformity / standards

11.1 CE



We declare that this product conforms to CE standards.

The product name is to be found on the name plate on the back of the housing.

11.2 Product standards

The machine satisfies the following requirements and standards:

2004/108/EC EC EMC Directive Directive of the Council on the approximation of the laws of the Member States relating to electro-magnetic compatibility.	
2006/95/EC EC Low Voltage Directive Directive 2006/95/EC of the European Parliament and of the Council of 12 December 2006 on the approximation of the laws of the Member States relating to electrical equipment designed for use within certain voltage limits.	
EN 55011 (2007 + A2:2007) radiated emissions, limit value class / group 2, class A	
EN 61000-6-2 (2005) immunity	
IP20 protection	IEC 60529

Relyon Plasma GmbH

Weidener Strasse 16
93057 Regensburg
Germany

Phone: +49-941-60098-0
Fax: +49-941-60098-100
E-mail: info@relyon-plasma.com
<http://www.relyon-plasma.com>