

plasma[®]brush

Operating instructions

- Gas supply package
- Emergency off switch



Thank you for purchasing a high-quality **relyon plasma** GmbH product.
To get the best from your product, please read these instructions carefully.



Important!

Read these instructions carefully before assembling, installing and starting up the machine!

Always follow the safety instructions! Failure to follow the safety instructions may result in accidents, serious injury and serious damage to the machine.

The product may only be started up and operated by trained and qualified persons!

Train your staff! The operator / user is responsible for ensuring that personnel have fully understood the operation of the machine and the safety requirements.

© Copyright **relyon plasma** GmbH 2016.

All rights reserved. All rights reserved.

Text, images and diagrams and their layout are protected by copyright and other laws. Unauthorised copying and distribution of this document and the utilisation and communication of its contents are strictly prohibited unless expressly authorised. Offenders will be held liable for the payment of damages. All rights reserved in the event of a patent, utility model or ornamental design registration being granted.

Original operating
instructions

1	Safety	4
1.1	Residual risks.....	4
1.2	Information and obligations for the operator	4
1.3	Intended use	4
1.4	Impermissible operating conditions.....	5
2	System description	6
2.1	Function	6
2.2	System overview	6
2.2.1	Description of the components	6
2.2.2	Scope of delivery	7
3	Transport / storage	8
4	Unpacking and installation	8
4.1	Unpacking	8
4.2	Installation requirements	8
4.3	Installation	9
4.3.1	Gas supply package installation (1000603700).....	9
4.3.2	Installation emergency off switch for PS2000 (1000603600)	10
5	Operation	12
5.1	Characteristic of the preadjusted throttle	12
6	Environment	13
6.1	Disposal	13

1 Safety

The system was designed in accordance with the relevant international standards. However, as with any technical product, hazards may arise if the system is not used properly or is used for purposes other than its intended use.

Working with the system can be dangerous and may result in serious or fatal injury. It is therefore essential to protect yourself and others.

In addition to the safety instructions in this document, you must also comply with general safety standards.



Caution - Danger!

When working with the system, please note and observe the safety instructions and requirements in these operating instructions because non-compliance may result in serious or fatal injury.

1.1 Residual risks

This system has been manufactured in accordance with the current state of the art. However, it is impossible to eliminate residual risks.

Always adhere to the following safety instructions:



Tripping hazard!

Lay the connection cables in suitable cable trays. Lay cables such that they do not present a tripping hazard.

1.2 Information and obligations for the operator

- Ensure that:
 - Operating personnel have read and understood these operating instructions.
 - Anyone working near the machine is made aware of the dangers and is provided with the necessary protective equipment.
 - Repairs are only carried out by qualified persons.
- In particular, make operating personnel aware of the safety instructions in this document.
- Always keep the system in fully functional condition.
- Any modifications made to the machine will invalidate the operating licence and the warranty. Exception: Such modifications are expressly authorised by the manufacturer.

1.3 Intended use

The system is intended solely for operation with the PS2000 high-voltage source and a plasma generator from **relyon plasma** GmbH.

Coupled with a suitable plasma generator, the machine is intended solely for the plasma treatment of surfaces (metals, textiles, glass, plastics) to activate, clean, coat or remove residue at atmospheric pressure.

Under no circumstances may the system be used by non-trained persons.

1.4 Impermissible operating conditions

The system must not be operated under the following conditions:

- In explosive (Ex) zones
- In areas with severe build-up of dust
- Where there is excessive air humidity (>80% rel.)
- Where temperatures are outside of 0 – 40 °C or 32 – 104 °F.
- Where there are strong vibrations



Note!

Please also observe the information in the operating instructions of all additional components connected to the system.

2 System description

2.1 Function

The components of the gas supply package are the basic elements of gas treatment for the operation of a Plasmabrush®PB3.

The emergency off switch components are used to configure a basic safety circuit for the PS2000 current source.

2.2 System overview

2.2.1 Description of the components

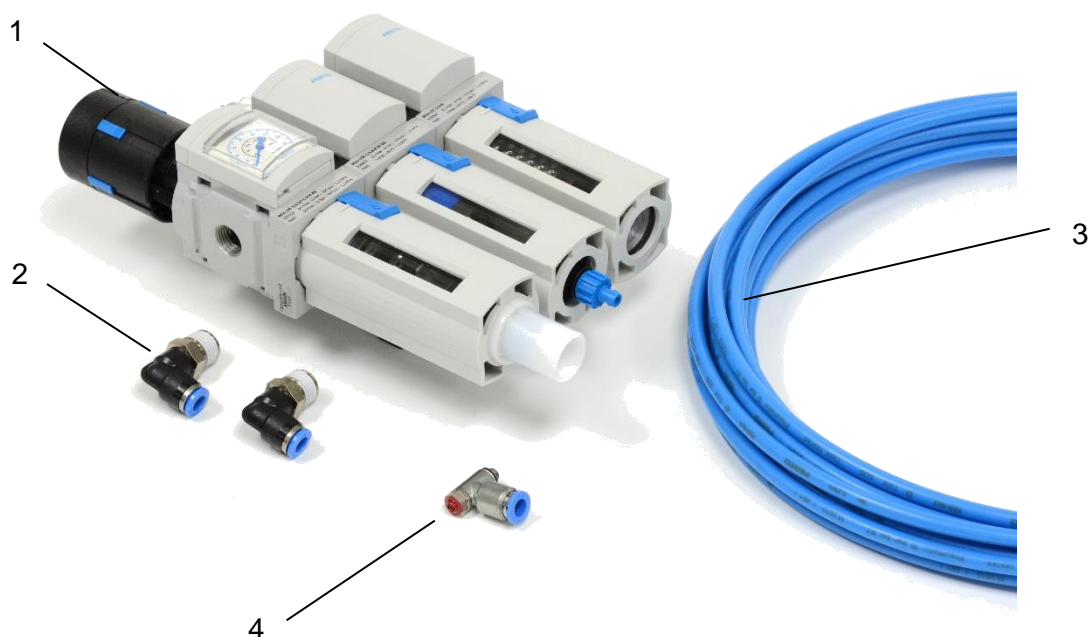

Gas supply package (item No. 1000603700)

No.	Components
1	MSB4 maintenance unit
2	L screw-in fitting
3	PEN plastic hose, Ø 6x1 mm, length: 15 m
4	PB3 throttle, preadjusted

The maintenance unit consists of the following components

- Manual filter regulator with manometer, $p_{\text{permit}} = 1.5$ to 14 bar, filter fineness: 5 μm
- Fine and ultra-fine filter, filter fineness: 0.01 μm
- Active carbon filter



Emergency off switch for PS2000 (item No. 1000603600)

No.	Components
1	Emergency stop / emergency off switch
2	Connection cable, length: 5 m
3	Circular plug connector for connection to PS2000
4	Cable screw-in connection
5	Locknut for cable screw-in connection

2.2.2 Scope of delivery

Gas supply package (item No. 1000603700)

The scope of delivery includes the following components:

- MSB maintenance unit
- L screw-in fitting (2 pieces)
- PEN plastic hose, Ø 6x1 mm, length: 15 m
- PB3 throttle, preadjusted
- Operating instructions

Emergency off switch for PS2000 (item No. 1000603600)

The scope of delivery includes the following components:

- Emergency stop / emergency off switch
- Connection cable, length 5 m
- Circular plug connector
- Cable screw-in connection with locknut
- Operating instructions

3 Transport / storage

- Protect the system from dirt and foreign objects.

4 Unpacking and installation

4.1 Unpacking

- Carefully open the packaging.
- Take the components out of the packaging.

4.2 Installation requirements

Before installing the machine, the following points must be met:

- The components must be undamaged.
- Only a trained electrician may wire the system.
- Observe all installation requirements and safety notices of the components/machines that are also connected.
- A gas supply installed at the factory must be present (e.g. central compressed air system or gas cylinder). Please refer to the operating instructions of the respective connected machine for the gas type quality requirements



Emergency stop circuit

The emergency stop circuit may only be wired and started up by a trained electrician.

4.3 Installation

4.3.1 Gas supply package installation (1000603700)

To install the system, carry out the following steps in the order specified:



Compressed air lines

Caution! Make sure the system is depressurised before you start the installation process.

1. Insert both L screw-in fittings into the maintenance unit.
2. Cut the supplied hose to the desired length and connect the hose to the plasma generator in the screw-in fitting on the right side. A hose length of ≤ 10 m is recommended.
3. Insert the hose from the gas supply into the screw-in fitting on the left side.
4. Mount the maintenance unit in an upright/vertical position.

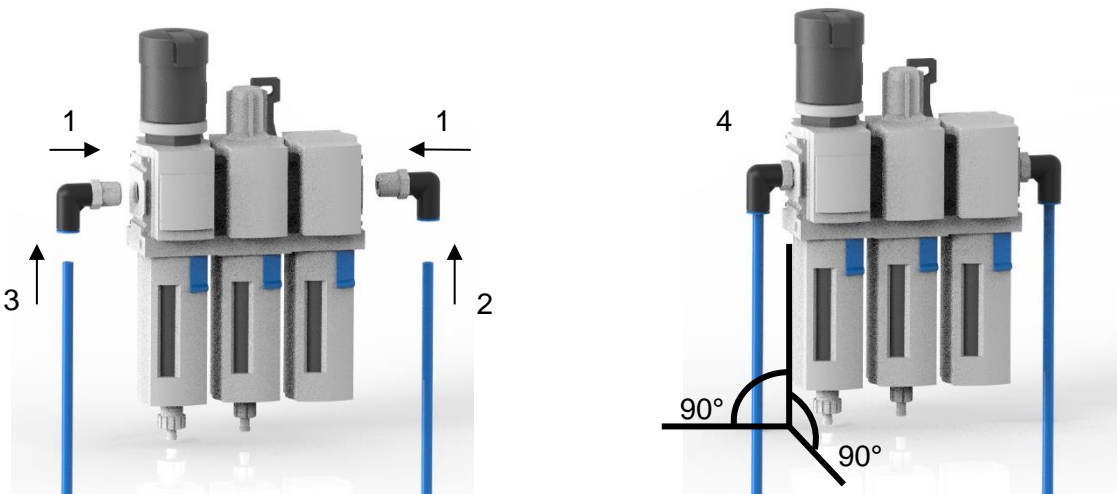

Maintenance unit position

The maintenance unit must always be operated in an upright/vertical position, otherwise faults may occur.

5. Unscrew the screw-in fitting mounted at the factory from the plasma generator.
6. Insert the preadjusted throttle into the plasma generator and connect the hose. The throttle is supplied in a preadjusted state with locking varnish. By changing the setscrew,

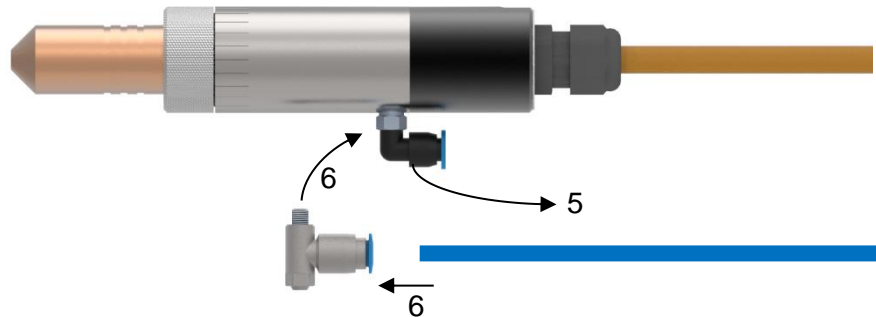

the pressure/flow ratio no longer corresponds to the characteristic in point 5.1.

7. Check all connections to ensure they are secure and do not leak before pressurising the system.

✓ The system is installed.

4.3.2 Installation emergency off switch for PS2000 (1000603600)

To install the system, carry out the following steps in the order specified:

1. If necessary, cut the cable to your required length and terminate the cable ends for the wiring properly.
2. Insert the cable screw-in connection into the emergency stop switch, wire the cable in accordance with the wiring diagram enclosed and secure the cable from sliding by tightening the cable screw-in connection.

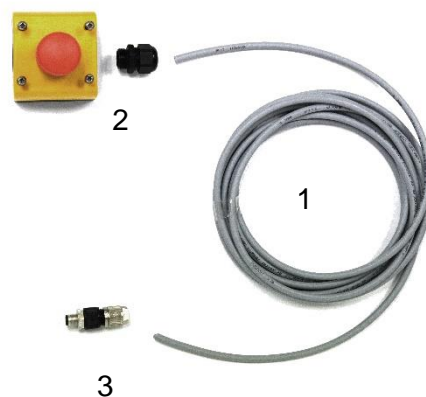

- Connect the circular plug connector to the other cable end in accordance with the wiring diagram. The circular plug connector supplied consists of four individual parts which have to be plugged/screwed together as shown.



- Check the emergency off switch to make sure it functions properly before commissioning.
- Connect the emergency off switch to the intended socket on the rear side of the PS2000 current source.

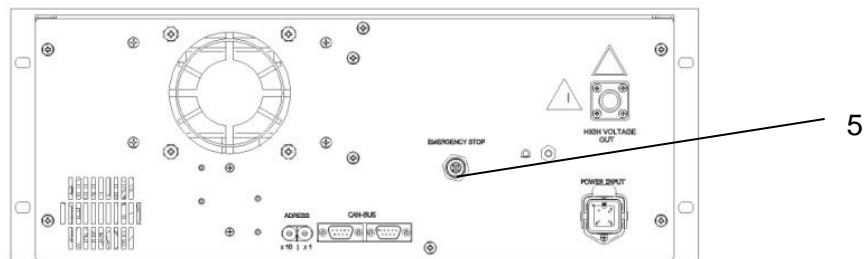

Connection assignment and connection principle of the emergency off switch display:

- PIN 1: +24 V output**
- PIN 2: 0 V/GND output**
- PIN 3: +24 V input (+/- 10%)**
- PIN 4: 0 V input**

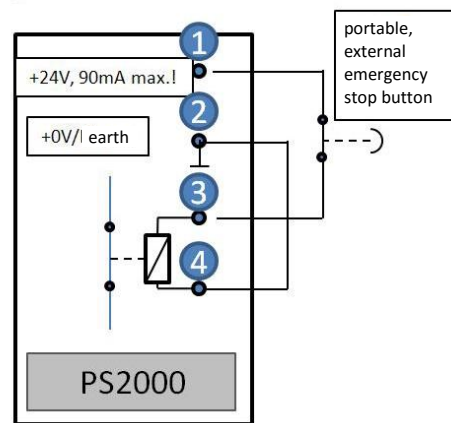

Emergency stop circuit

The emergency stop circuit may only be wired and started up by a trained electrician.

- ✓ The system is installed.

5 Operation

5.1 Characteristic of the preadjusted throttle

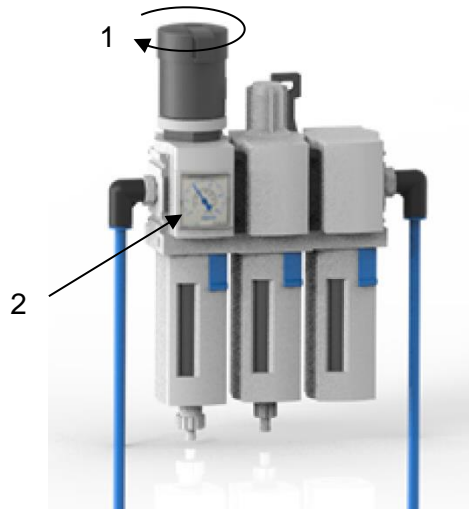

1. Adjust the gas pressure by turning the maintenance unit on the pressure reducer.
2. Read off the set value on the display.
3. The corresponding flow results from the following characteristics. Please refer to the operating instructions of the connected machines for the permissible operating parameters.

Characteristic for compressed air (T=25 °C)

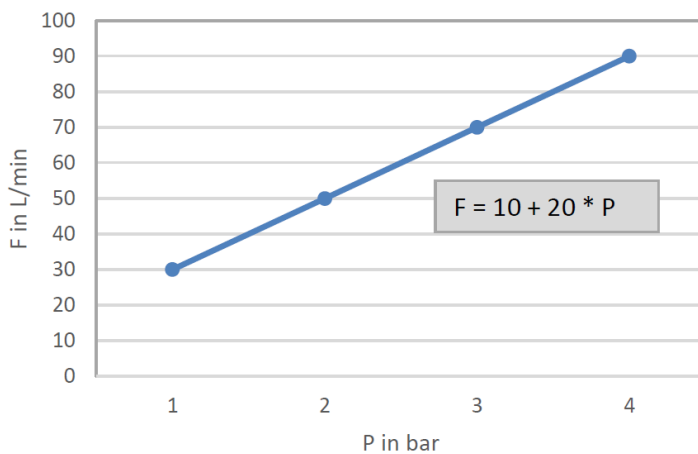

Compressed air characteristic at room temperature (1 m hose connection with $D_i=4$ mm)

Pressure	Gas flow
1 bar	30 l/min
2 bar	50 l/min
3 bar	70 l/min
4 bar	90 l/min



Characteristic validity range

The characteristic is only valid if the throttle is not moved and the hose length ($D_i=4$ mm) is 1 m. For a hose length that is 5m, the pressure must be increased by 10%. For a hose length that is 10 m, the pressure must be increased by 20%.

6 Environment

6.1 Disposal



Consider the environment.

Electrical and electronic equipment used must not be disposed of along with normal waste.

- The machine contains valuable materials that can be recycled. Take the machine to a suitable collection point.

relyon plasma GmbH

Weidener Strasse 16
93057 Regensburg
Germany

Phone: +49-941-60098-0
Fax: +49-941-60098-100
E-mail: info@relyon-plasma.com
www.relyon-plasma.com