piezobrush[®] PZ3: Ozone control

Version: October 6th, 2021

Dariusz Korzec and Stefan Nettesheim



Abstract

The subject of this whitepaper is the practical methods of avoiding harmful concentrations of ozone at workplace during piezobrush[®] PZ2 or piezobrush[®] PZ3 operation. Simple calculations are used to predict how fast the harmful ozone concentration in the air is reached. Different measurements of ozone concentration are briefly reviewed. The UV absorption method is applied for the characterization of the spatial distribution of ozone concentration in the vicinity of the piezobrush[®] PZ3. Depending on the way of the piezobrush[®] PZ3 operation, different configurations of gas extraction, filters, and catalytic destructors can be applied. The example calculations show, how to size and properly apply such ozone control means.

Keywords: ozone, ozone concentration, ozone production rate, catalytic destruction, active carbon filter

Contents

1	Introduction	2
2	Ozone	2
2.1	Technical methods of ozone production	3
2.2	Ozone concentration	3
2.3	Ozone concentration levels	3
2.4	Ozone production rate	4
2.5	Ozone decomposition	4
3	Ozone concentration calculation	6
3.1	Ozone concentration in airflow	6
3.2	piezobrush [®] PZ3 vs. piezobrush [®] PZ2	6
3.3	Safe dilution	7
3.4	Ozone concentration in closed volume	7
4	Ozone concentration measurement methods	8
4.1	Colorimetric gas detector tubes	8
4.2	Metal oxide semiconductor sensor	8
4.3	UV light absorption	8
5	Experimental determination of ozone production rate	9
5.1	Ozone generation in airflow	9
5.2	Ozone concentration for production rate	10
5.3	Ozone concentration vs. CDA flow	11
5.4	Influence of power on ozone production rate	12
5.5	Determination of production rate in closed volume	13
6	Ozone spreading in space	13
6.1	Influence of gas extraction	15
6.2	Influence of vertical and horizontal distance	17
6.3	Radial distribution	19
7	Conclusion	19
	Bibliography	20

1 Introduction

Atmospheric pressure plasmas are broadly used in research and production. The main mechanism of their action is the production of reactive oxygen-nitrogen species (RONS). Depending on the character of the discharge, either more nitrogen oxide or more ozone is produced. The discharges based on an atmospheric arc, such as pulsed atmospheric arc (PAA) produce predominantly different types of nitrogen oxides (NO_x), since high temperatures occurring in arc promote the nitrogen oxidation. The cold type of air discharges, such as corona or piezoelectric direct discharge (PDD) promote chemical reactions producing ozone as a long-living product. piezobrush[®] PZ2 and piezobrush[®] PZ3 belong to this group of plasma sources.

On one hand, it is advantageous to maximize the concentration of RONS in the plasma fume, because it allows higher processing speeds. On the other hand, the same species which are indispensable for the technological process, are, in high concentrations, harmful to living species. It can be advantageous if the plasma is used for disinfection or sterilization. However, it is dangerous for humans to be exposed to such gases. To avoid this hazard, proper handling of the plasma device and gas management is needed. This report gives guidelines for estimation of the hazard due to ozone and shows the ways to avoid it.

2 Ozone

Ozone, or accordingly to systematic IUPAC name: trioxygen, is an unstable gas that is produced in air or other oxygen-containing gas mixtures, as a result of UV light illumination, mainly at 172 nm [27] and 184.9 nm wavelengths, [21] electron bombardment or chemical processes. Most important physical properties of ozone are summarized in Table 1.

Table 1: Physical properties of ozone.

Description	Values	Units
Molar mass	47.997	g/mol
Density at STP ¹	2.144	kg/m ³
Solubility in water at STP	1.05	g/dm ³
Half-lifetime (HLT) in dry air at 24°C	1500	min
Standard enthalpy of formation	142.67	kJ/mol

¹In chemistry, IUPAC uses since 1982 the standard temperature and pressure (STP) defined as the temperature of 0°C = 273.15 K and an absolute pressure of exactly 1 bar = 100 kPa.

2.1 Technical methods of ozone production

The established methods of ozone generation are by photochemical generation [9], for example by Xe₂ excimer lamps [12], electrochemically [6, 28], and by electrical discharges [4, 3]. The last one can be subdivided in ozone generation by dielectric barrier discharge (DBD) in oxygen [11] and air [19], by surface dielectric barrier discharge (SDBD) [22, 29] by Corona discharges in air [5], oxygen, and carbon dioxide [30], and by piezoelectric direct discharges (PDD) [17, 32], both in air and in oxygen [33, 16]. The PCPG generates ozone in any oxygen-containing environment.

2.2 Ozone concentration

The amount of ozone in some media can be described quantitatively by ozone concentration. The most frequently used one is the concentration of ozone in the air or water. In this study, the focus is on ozone concentration in the air. Different definitions of this are commonly used.

The most popular one is part per million (ppm). ppm is closely related to part per billion (ppb). Both are related to %:

$$1\% = 10^4 \text{ ppm} = 10^7 \text{ ppb}$$

The ppm and ppb can be written with additional letter: ppm(v) or ppm(m) which means, that the units refer to the volume (v) or molar amount (m).

A different type of unit for ozone concentration is the mass of ozone per unit volume of gas. The most frequently used ones are $\mu\text{g}/\text{m}^3$ or g/m^3 . The more precise version of the last unit is g/Nm^3 where N refers to NTP conditions².

The rule of thumb for recalculation between these two types of units is:

$$1 \text{ ppb} = 2 \mu\text{g}/\text{m}^3$$

2.3 Ozone concentration levels

Ozone occurs naturally in the atmosphere, where it has great biological and meteorological significance [3]. Typically its concentration in the troposphere does not exceed 10 ppb (Table 2). The human nose is quite sensitive to ozone and detects it at the concentration of 20 ppb. This can vary depending on personal abilities and exposure to increased ozone concentrations (getting used to, accommodation effect). Table 2 shows characteristic ozone concentration limits in open and closed environments.

Table 2: The ozone concentration thresholds.

Description	Ozone in ppm	Ozone in $\mu\text{g}/\text{m}^3$
Natural concentration in the troposphere	0.0001–0.01	
Typical instruments for air cleaning	0,015-0,05	
Smell threshold	0.02	40
Workplace 8 hours mean value (valid before 2005)	0.06	120
Smog alarm	0.09	180
Alarm	0.12	240
Immediately dangerous to life or health (IDLH) (1957)	5	
Acute inhalation toxicity in humans	9	
Lethal for mouse, rat or pig after 3 h exposure	~20	
Lethal for humans after 30 min exposure	~50	
In plasma gases of piezobrush [®] PZ2	120	
Inactivation of bacteria and viruses	100–200	
In plasma gases of piezobrush [®] PZ3	240	
Maximum reachable in air under normal conditions	4500	
Commercial O ₃ generators working with air	up to 25 000	
With SDBD in 70%O ₂ + 30%CO ₂	35 000	
Commercial O ₃ generators working with O ₂	up to 60 000	

The influence of ozone concentration on humans depends not only on the ozone concentration but also on the duration of the exposition to ozone. Figure 1 shows this influence.

2.4 Ozone production rate

An important characteristic of an ozone-generating instrument is its ozone production rate, defined as the amount of ozone produced in a time unit. Typically, this amount is expressed in grams per hour. As shown in Section 5, the ozone production rate of piezobrush[®] PZ2 or piezobrush[®] PZ3 working with 100% power, is about 0.08 g/h. Knowing this value, the ozone concentration in either a closed volume or in the gas flow can be calculated. The simple formulas for such calculations are presented in Section 3.

2.5 Ozone decomposition

Gas with a very high ozone concentration cannot be released in the ambient without neutralization. At the temperature of 24°C and relative humidity of 45%, the half-lifetime (HLT) of ozone is 11 h [24]. The factors that reduce the HLT of ozone are:

- High humidity contributing to ozone destruction due to chemical reactions with OH and HO₂ radicals [13, 24],

²The normal temperature and pressure (NTP) is used (NIST) for the temperature of 20°C = 293.15 K and the absolute pressure of 1 atm = 101.325 kPa).

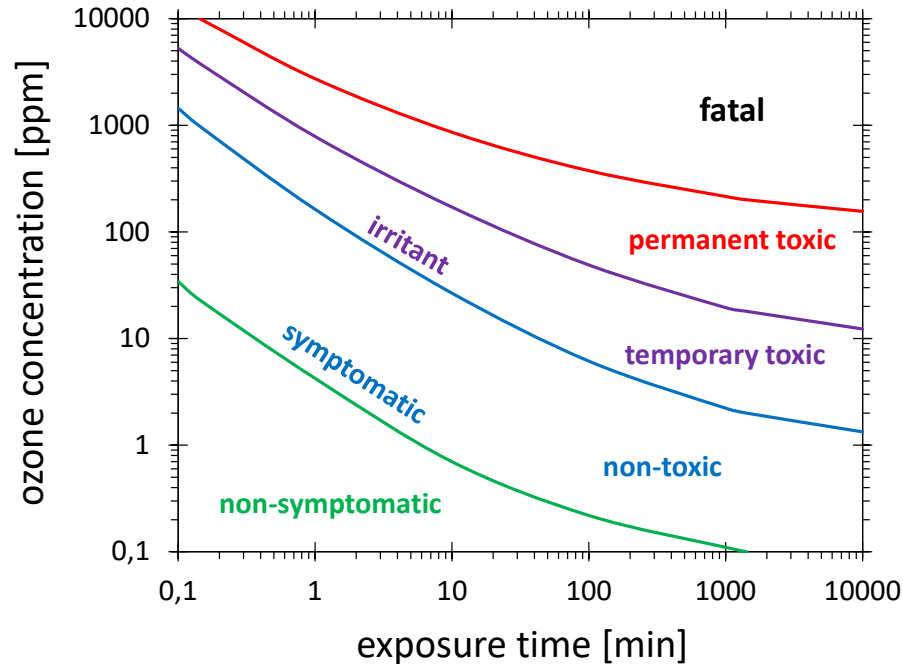

Figure 1: Influence of ozone on humans depending on exposure time and concentration. Source: <https://www.lenntech.com/ozone-and-humans.htm#ixzz4nkJ8Exrk>

- Elevated temperature (see discussion in section 5.4) causing thermal decomposition [2],
- Presence of surfaces containing water solutions with high pH-values [15, 31],
- Presence of carbon [26] and some organic substances,
- Presence of catalytic materials such as metals and metallic oxides [1], especially MnO_2 [8].
- UV illumination in wavelength range causing photolysis (200 – 300 nm) [23], and
- High (several %) ozone concentration activating more efficient reaction channels for ozone destruction.

Some of these mechanisms can be used for intentional destruction of ozone. The most spread is the application of activated carbon filters. Their main drawback is that the activated carbon is consumed by reactions with ozone and has to be replaced after wear.

No significant wear is observed by catalytic filters, based mainly on mixtures of MnO_2 and CuO_2 [8, 25]. The problem with catalytic filters is that, they are selective. It means,

they remove very efficiently ozone, but much less effective, some other harmful substances present in plasma gases. These are either the nitrogen-based oxidizing species or ozonides, resulting from chemical reactions of ozone with plastics. They can also be “poisoned” by a number of chemical compounds.

3 Ozone concentration calculation

3.1 Ozone concentration in airflow

Knowing the airflow f_{air} and the ozone production rate of the PCPG the ozone concentration N_{O_3} in this airflow can be expressed as follows:

$$N_{\text{O}_3} = \frac{R_{\text{prod}} \cdot V_A}{f_{\text{air}} \cdot M_{\text{O}_3}} \quad (1)$$

where V_A is the molar volume, which is ca. 0.024790 m³/mol for the pressure of 1 bar and temperature of 25°C, and M_{O_3} is the molar mass of ozone (48 g/mol). Analyzing Equation (1) it is apparent that the ozone concentration can be decreased in two ways: by a decrease of production rate or by an increase of the airflow, resulting in dilution of the ozone. For maximum piezobrush[®] PZ3 production rate of 80 mg/h (see Section 5) in air, the ozone concentration is inversely proportional to the airflow and can be calculated using the numerical formula:

$$N_{\text{O}_3} = \frac{623 \text{ ppm} \cdot \text{SLM}}{f_{\text{air}}} \quad (2)$$

Let us use this formula for some practical estimations.

3.2 piezobrush[®] PZ3 vs. piezobrush[®] PZ2

Using Equation 2, the concentration of ozone flowing out of the piezobrush[®] PZ2 and piezobrush[®] PZ3 can be estimated. It is not the same value, because these two plasma generators work with different fans resulting in different gas flows. For piezobrush[®] PZ2 working with a gas flow of about 30 SLM, the ozone concentration in the open nozzle is 22.8 ppm. For piezobrush[®] PZ3 operated with full power (8 W) and working with a gas flow of about 10 SLM, the ozone concentration in output flow is 62.3 ppm. The much higher ozone concentration for piezobrush[®] PZ3 results in higher process efficiency.

3.3 Safe dilution

Using converted Equation (2), for known production rate (80 mg/h) the airflow of the gas extraction system can be calculated, which allows for dilution of the produced ozone below the smog alarm level of $180 \mu\text{g}/\text{m}^3 = 0.09 \text{ ppm}$ (Table 2).

$$f_{\text{air}} = \frac{623 \text{ SLM} \cdot \text{ppm}}{N_{\text{O}_3}} = 623/0.09 \text{ SLM} \approx 6900 \text{ SLM} = 415 \text{ m}^3\text{h}^{-1} \quad (3)$$

Since the throughput of blowers used for gas extraction is typically expressed in $\text{m}^3 \text{ h}^{-1}$, the value is recalculated to these units. This value is compatible with the suction power of typical work-place extraction terminals working without active carbon filters and guiding the gas to the environment.

3.4 Ozone concentration in closed volume

Assuming a constant production rate R_{prod} , the mean ozone concentration N_{O_3} reached after PCPG operation time of t in a constant volume V_0 can be expressed as:

$$N_{\text{O}_3}(t) = \frac{R_{\text{prod}} \cdot V_A}{V_0 \cdot M_{\text{O}_3}} \cdot t \quad (4)$$

For simplicity, Equation (4) does not take into account: (i) the ozone destruction rate, (ii) the pumping away of the air by ozone sensor, and (iii) the decrease of the volume due to the reduction of the mole amount of gas (O_2 conversion in O_3), because for typical cases their influence is negligible.

The non-stop operation time of piezobrush[®] PZ3 is limited to 5 min, after which the device switches off automatically. In this case, in the hall in which the experiments were conducted (see Section 6) with sizes of $10 \text{ m} \times 8 \text{ m} \times 5 \text{ m} = 400 \text{ m}^3$, assuming that the hall is closed and not ventilated, the ozone concentration of 8 ppb is reached. It is below the smell limit.

Let reformulate Equation (4) to calculate the time elapsing before some threshold value of ozone concentration is reached:

$$t_{\text{th}} = \frac{N_{\text{O}_3} \cdot V_0 \cdot M_{\text{O}_3}}{R_{\text{prod}} \cdot V_A} \quad (5)$$

Taking into account the values of the constants and recalculation factors, the linear dependence on volume obtained for the guide value for ozone concentration in workplaces of 60 ppb is:

$$t = 5.78 \text{ s} \cdot \text{m}^{-3} \cdot V_0 \quad (6)$$

For room of $3 \text{ m} \times 3 \text{ m} \times 3 \text{ m} = 27 \text{ m}^3$, this time is $156 \text{ s} = 2 \text{ min } 36 \text{ s}$. This result means that in an unventilated small office room, the ozone concentration can reach 0.06 ppm (Table 2) after only a few minutes of piezobrush[®] PZ3 operation.

4 Ozone concentration measurement methods

The production rate used for the calculation of ozone concentration in Section 3 was determined based on different measurements. In the following, the most popular techniques are summarized.

4.1 Colorimetric gas detector tubes

Low-cost and easy-to-use tools for detecting the presence of ozone are the colorimetric gas detector tubes available from a wide range of manufacturers [10]. In a typical colorimetric gas detector tube, a predetermined volume of air is pumped through a tube using a portable pump. The tube has a layer that indicates ozone by changing color. Depending on the amount of ozone that has passed through the tube the length of the zone which has changed color will be different. The drawbacks of this method are low accuracy, need for consumables, and no time-dependent monitoring.

4.2 Metal oxide semiconductor sensor

A handheld ozone sensor A-22 of ECO-Sensors is equipped with heated metal oxide semiconductor sensor. It allows the measurement of ozone concentration without air pumping, which is especially suitable, if ozone concentrations in very small volume are to be measured, for which the pumping cannot be applied. A-22 automatically selects one of its ozone concentration ranges: 30 ppb to 1.999 ppm and 2.00 ppm to 20.00 ppm . The upper concentration limit of this sensor is 19.99 ppm . The drawback of such sensors is a long response time and the need for frequent calibration recommended monthly and replacement of the sensor module, annually. Since this method does not require pumping, it is especially suitable for the determination of ozone concentration in very small volumes.

4.3 UV light absorption

The high-accuracy measurement of ozone concentration can be conducted utilizing the UV light absorption in the wavelength range of 200 to 300 nm [23]. For this study two ozone sensors based on such a principle were applied.

Ozone Analyzer UV-100 of ECO Sensors that allows ozone concentration measurements in the range of 10 ppb to 999 ppm is used for higher ozone concentrations as shown in Sections 5.1 and 5.5.

For precise determination of the ozone concentration in the range of 0.2 ppb to 10 ppm (see Section 6), the UV photometric ozone analyzer O342e of Environnement S.A. was used. The sample flow rate of this instrument is 1 SLM. The measurement was performed each 10 s. The drawback of this method is the comparatively high cost.

5 Experimental determination of ozone production rate

The ozone concentration can be measured directly but is not a suitable parameter for characterizing PCPG efficiency because the result strongly depends on airflow. A more suitable parameter for this purpose is the production rate, defined as mass of ozone produced per time unit. In the next sections, the two methods of production rate determination: in the gas flow and in the closed volume are presented. Both of them are applied and give the same value of production rate for CeraPlas[®] F-based devices.

5.1 Ozone generation in airflow

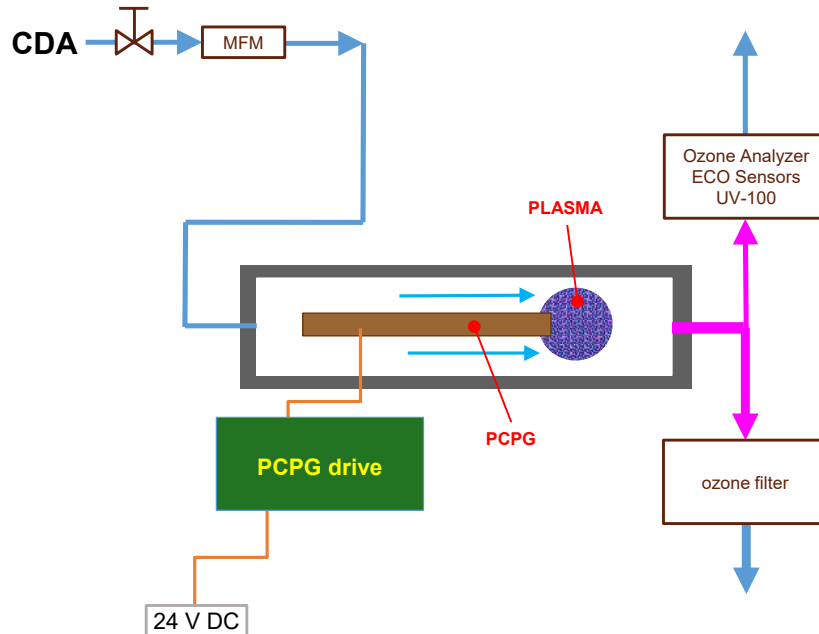

Figure 2: Measurement of the concentration of ozone generated by PCPG in the flow of CDA.Setup.

To obtain accurate ozone concentration values, the measurements were conducted with

CeraPlas[®]F, embedded without driver electronics in the module with gas flow. The PCPG can be operated in CDA or a mixture of nitrogen and oxygen. The CDA flow is controlled by a needle valve and MFM of FESTO. The nitrogen and oxygen flows are controlled by the MFC of MKS. The generic setup used for ozone generation in the flow of compressed dry air (CDA) is shown in Figure 2.

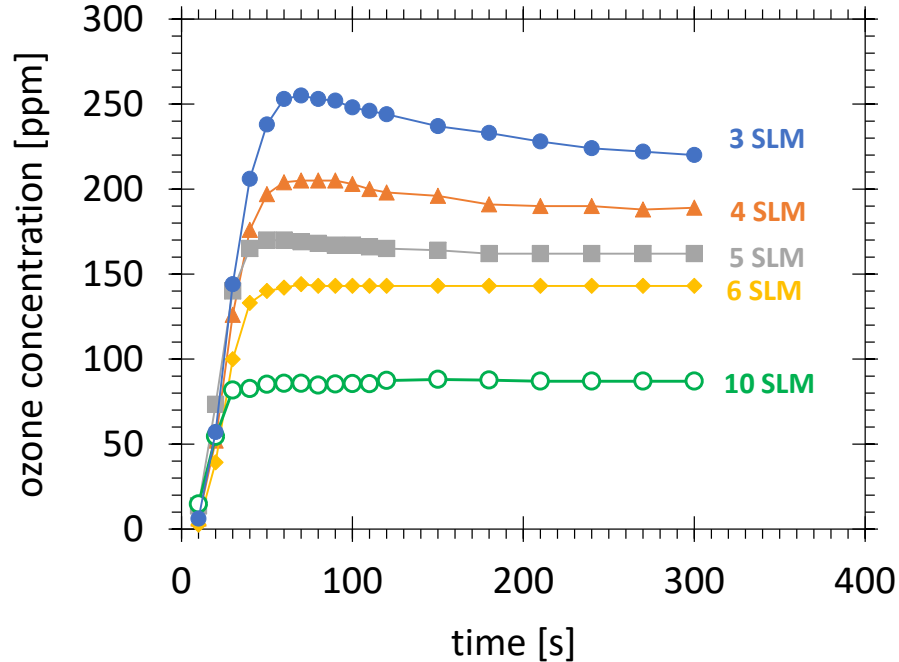

Figure 3: Measurement of the concentration of ozone generated by PCPG in the flow of CDA. Concentration of ozone as a function of operation time for five compressed dry airflows. The piezoelectric transformer power is 8.3 W.

5.2 Ozone concentration for production rate

After switching on the PCPG power supply, a rapid increase in the ozone concentration can be observed, as shown for five CDA flows in Figure 3. For flows below 6 SLM the maximum concentrations are reached after about 60 s. Then, the ozone concentration decreases with time. The lower the flow, the stronger the drop of ozone concentration and the longer the time it takes to reach the stable value. For 3 SLM, the concentration drops by 15% from its maximum value after 5 min after switching on the power, and the asymptotic value is not reached yet. For 5 SLM, the drop is less than 5% and the stable value is reached after 3 min. The proposed physical reason for this effect is an increase in the PCPG temperature. The PCPG is heated mainly due to the mechanical and also, electrostatic losses [7]. Since the PCPG block is made of PZT ceramics with poor thermal conductivity ($\approx 1.4 \text{ W} \cdot \text{m}^{-1} \cdot \text{K}^{-1}$), [18] and high specific heat ($\approx 100 \text{ J} \cdot \text{mole}^{-1} \cdot \text{K}^{-1}$) [20]

at room temperature, it takes several minutes for the heat from the inner part of the PCPG to reach the surface and a thermal balance can be established. The time needed to reach the thermal equilibrium increases with a decrease in CDA flow, due to degrading cooling of the PCPG. The fan for air cooling the piezobrush[®] PZ2 and piezobrush[®] PZ3 is chosen to deliver an airflow, which is always higher than 6 SLM, resulting in minimal thermal drift after time longer than 1 min. Consequently, the ozone concentration used for the determination of the ozone production rate is measured after 60 s from a cold start.

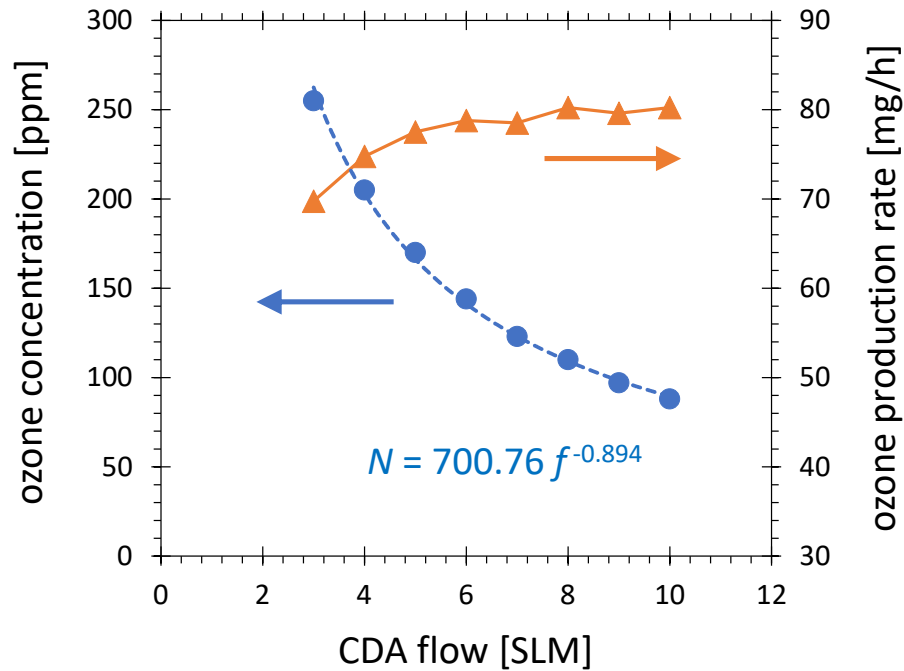

Figure 4: Ozone concentration as a function of CDA flow, measured at PCPG power of 8.3 W

5.3 Ozone concentration vs. CDA flow

The concentration of ozone as a function of CDA flow is visualized as a blue plot in Figure 3. According to the fitting curve of this plot, the ozone concentration decreases almost inversely proportional to the CDA flow, which confirms the predictions of Equation 1. The higher the flow, the stronger the dilution grade of ozone, and the lower the expected activation efficiency. To maximize the activation efficiency, the ozone concentration must be maximized by minimizing the airflow. The limiting factor with regard to minimization of the airflow is the PCPT cooling requirements, which are dependent on the power coupled in the system.

The production rate of ozone R_{prod} can be calculated from the ozone concentration N_{O_3} using the following equation:

$$R_{\text{prod}} = \frac{M_{\text{O}_3}}{V_{\text{A}}} \cdot f_{\text{gas}} \cdot N_{\text{O}_3}, \quad (7)$$

derived from Equation 1.

Using the ozone concentrations from the blue plot and Equation (7), the production rates are calculated and visualized as a red plot in Figure 3. For gas flow higher than 5 SLM, only a small variation in the production rate is observed. With gas flow decreasing below 5 SLM, the ozone production rate decreases. This effect can be explained by the increasing temperature of the PCPG due to insufficient air cooling. With increasing temperature, the following processes can affect the ozone production rate:

- (i) Changes in the PCPG itself such as change of resonance frequency and input impedance.
- (ii) The less efficient ozone production. An increase of specific energy input in the discharge, due to higher power, leads to an increase of concentrations of nitrogen oxides, which react with atomic oxygen – the main species needed for ozone synthesis. This effect is known as discharge poisoning and can completely stop the ozone generation [14].
- (iii) The enhanced decomposition of ozone. From 100°C upwards, the thermolysis based on reactions with radicals [2] is an increasingly important loss mechanism of ozone.

The CDA flow below 3 SLM was not investigated, to avoid the thermal overload of the PCPG.

5.4 Influence of power on ozone production rate

In contrast to the piezobrush[®] PZ3, which has the constant input power of the piezoelectric transformer of 8.3 W, the ozone production of the piezobrush[®] PZ3 can be reduced by decreasing the power.

Figure 5 shows the production rate of piezobrush[®] PZ3 as a function of the input power. The production rate increased in power in the entire power range investigated. It reached the maximum value of 73 mg/h for 8 W. This value is slightly lower, than the one determined from Figure 4, due to the 0.3 W lower power and the presence of the ambient humidity in the plasma gas.

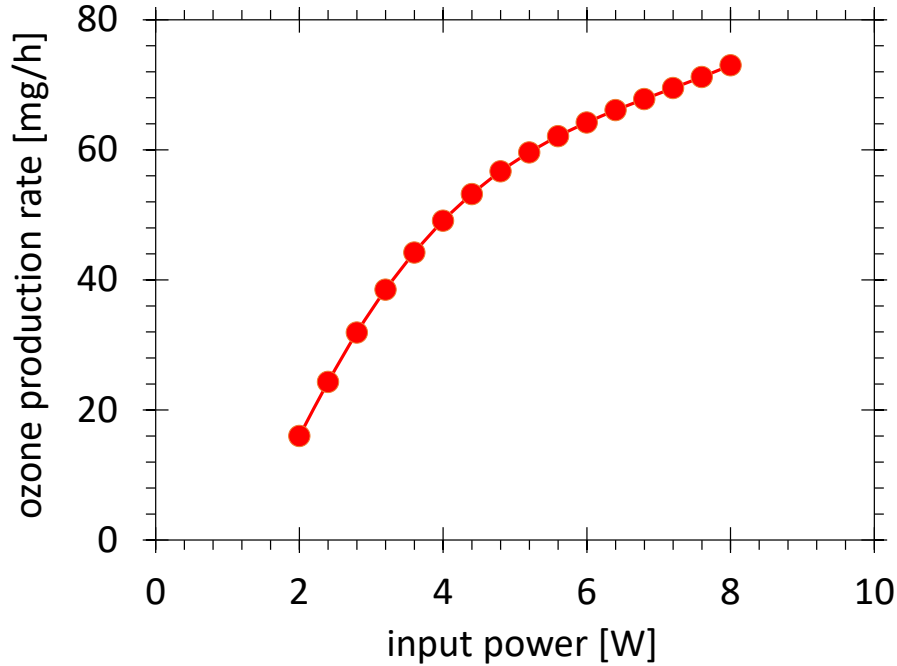

Figure 5: Ozone production vs. power of piezobrush[®] PZ3 operated with ambient air.

The increase in the ozone production rate is faster for power values below 5 W and slows down for higher values, which can be interpreted as a loss of ozone production efficiency (production rate per energy unit). This effect can be explained by the increasing temperature of the PCPG tip and the physical mechanisms listed in Section 5.3.

5.5 Determination of production rate in closed volume

Another method for determination of the production rate is based on the measurement of the ozone concentration in a closed volume in which the ozone source is working. According to Equation 4, this concentration should increase linearly with time. From the fitting line of such results, the production rate can be calculated. The setup for such measurement is shown schematically in Figure 6. The advantage of the polymer bag, in our case HDPE, is the adjustment of the volume to the changing conditions such as stoichiometry (O_2 converted in O_3), the temperature during plasma generator operation, and the suction of the sample gas by the ozone sensor.

6 Ozone spreading in space

The calculations of mean values of ozone concentration in airflow or closed space are presented in Section 3. These are idealized calculations assuming a homogeneous distribution of ozone in space. They do not take into account the real-time spreading in space

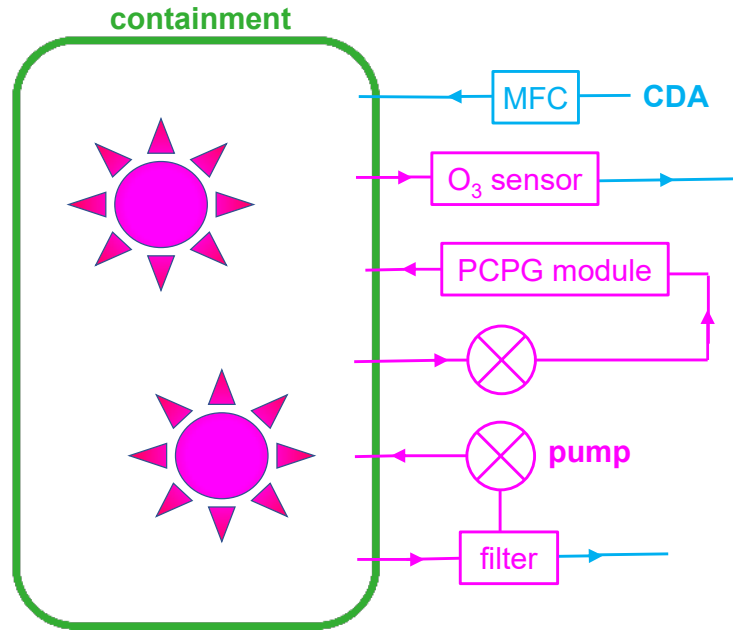

Figure 6: Setup. Measurement of the concentration of ozone generated by PCPG in constant volume of gas.

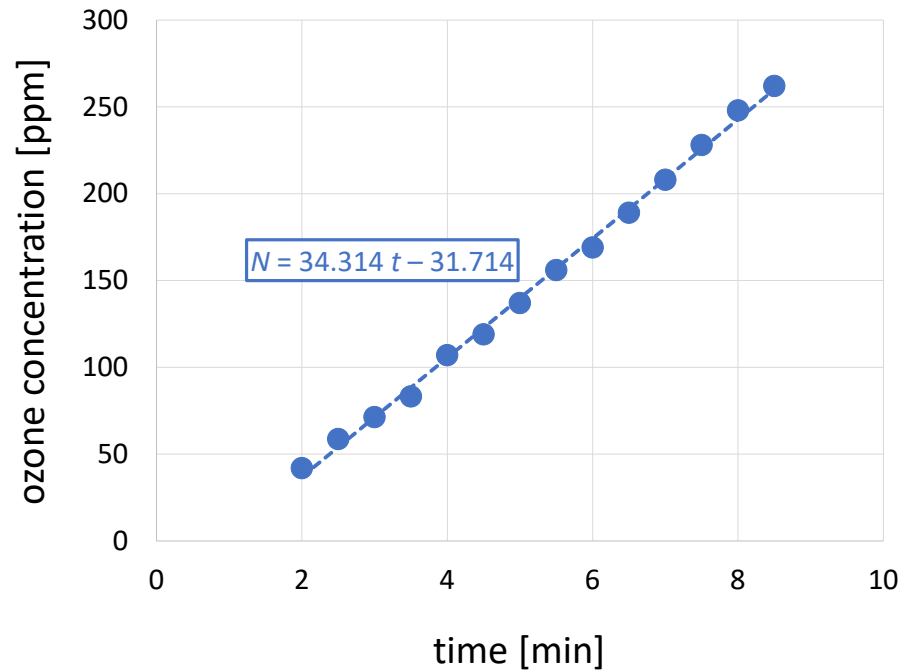

Figure 7: Ozone concentration as function of piezobrush[®] PZ2 operation time in 20 l bag.

of the ozone produced in a plasma generator. It can be expected that, despite low mean values, some zones of high ozone concentration are present. The aim of this section is to investigate the actual ozone distribution in the vicinity of the piezobrush[®] PZ3 and to determine the safe regions and conditions for ozone concentration not exceeding 60 ppb (Table 2). For these measurements, the piezobrush[®] PZ3 is positioned vertically, with plasma gas blown downwards. The investigated distances are shown in Figure 8. The ozone concentration measurement results presented in this section were obtained using the ozone sensor O342e described in Section 4.

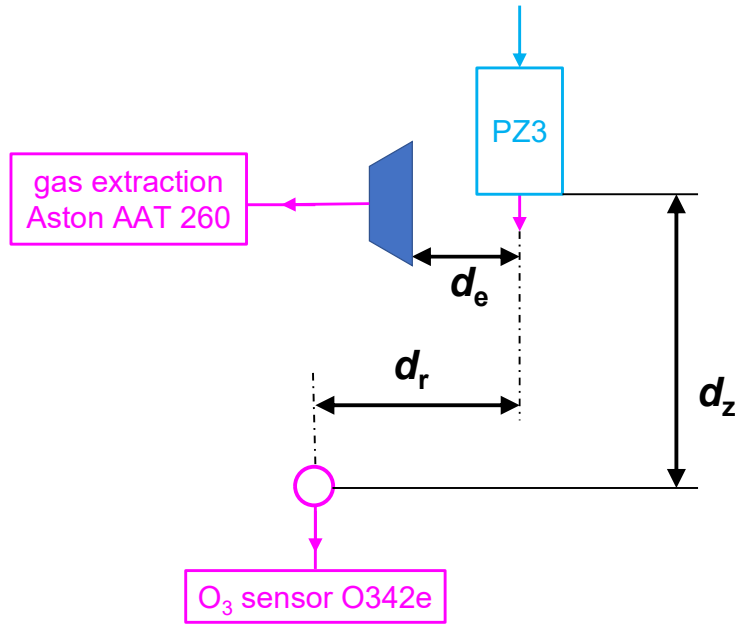

Figure 8: The geometrical configuration of instruments for measurement of the concentration of ozone generated by piezobrush[®] PZ3 for different positions in respect to the ozone sensor gas inlet and gas extraction conditions.

6.1 Influence of gas extraction

Figure 9 shows the time-dependent response of the ozone concentration at a distance of 250 mm from the piezobrush[®] PZ3 open nozzle on two minutes operation of piezobrush[®] PZ3 with full power (8 W) for different distances d_e between the piezobrush[®] PZ3 open nozzle and the funnel of the gas extraction. For active filtering, a funnel-shaped inlet of 100 mm diameter was connected to the active carbon filter station Aston AAT 260 with maximum suction power of 190 m³/h.

Without any gas extraction, the ozone concentration rises within 10 s from the background value of 5 ppb and reaches a stable value slightly over 2 ppm, which, accordingly to the

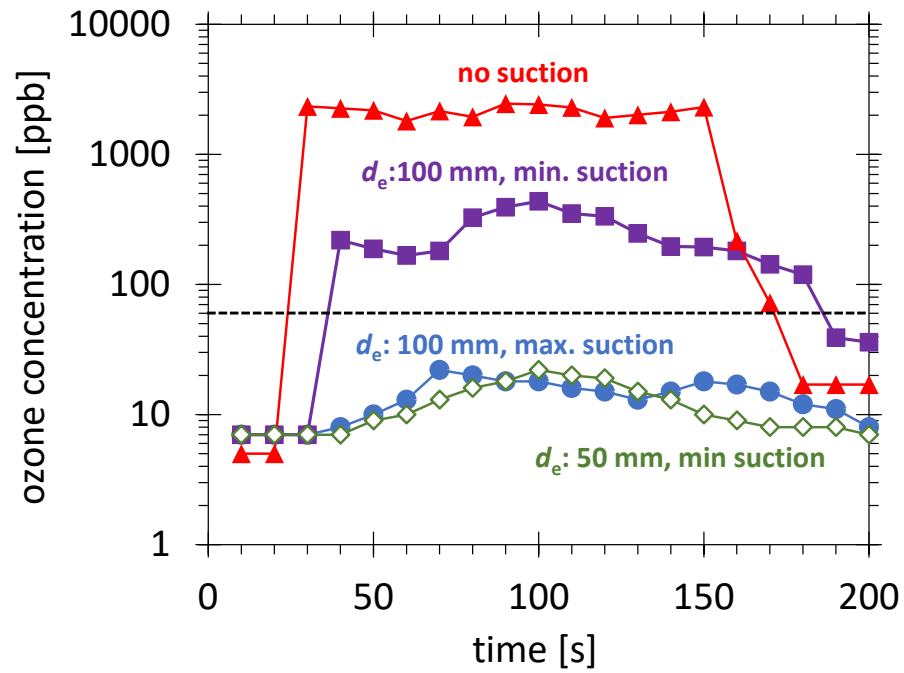

Figure 9: The time-dependent response of the ozone concentration on two minutes operation of piezobrush[®] PZ3 with full power (8 W), at constant vertical distance, $d_z = 250$ mm between the piezobrush[®] PZ3 open nozzle and the ozone sensor gas inlet, for different distances d_e between the piezobrush[®] PZ3 open nozzle and the suction funnel, and different gas extraction power levels.

plot in Figure 1, would be harmful to a person breathing such air for more than 2 min. After switching off the piezobrush[®] PZ3, it takes a little more time, about 30 s, to reach the plateau. The level of this plateau of 17 ppb decreases further much slower and reaches the starting value of 5 ppb after many hours, despite the large size of the hall in which the experiments were conducted.

Very important for effective ozone extraction is the distance of the extraction funnel from the piezobrush[®] PZ3 nozzle. For the short distance of $d_e = 50$ mm, the maximum reached value is 22 ppb, much below the limiting value of 60 ppb depicted in Figure 9 with the dashed line, even for the minimum power of the gas extraction of about 19 m³/h. However, the increase of the extraction funnel distance to up to $d_e = 100$ mm is sufficient to strongly exceed the limit value, reaching the maximum of 0.436 ppm.

To some extent, the increase of the distance between the extraction funnel and the nozzle can be compensated for by an increase in the gas extraction power. When applying the maximum suction power of 190 m³/h the maximum measured ozone concentration drops again to less than 60 ppb, reaching the maximum of 22 ppb. In both cases of efficient gas extraction, shortly after switching off the piezobrush[®] PZ3, the ozone concentration which is below 10 ppb is measured.

6.2 Influence of vertical and horizontal distance

The study on the influence of the distance between the piezobrush[®] PZ3 nozzle and the ozone sensor gas inlet was conducted in the same way, as in the previous section, but in Figure 10 the mean values reached between the 30th and 100th second of the ON time of the piezobrush[®] PZ3, are plotted.

The maximum mean concentration of 3.7 ppm was reached for the shortest distance of $d_z = 100$ mm. Lower distances were not tested, because the concentration values would exceed the limit of the ozone sensor of 10 ppm. The maximum mean concentration decreased exponentially with distance d_z , which resulted in a linear plot in a semilogarithmic scale in Figure 10. In the long distance, 400 mm and more, the measured ozone concentration was below the limiting value of 60 ppb, as depicted in the diagram with a dashed line. For the distance of 600 mm no measurable increase of the ozone concentration was observed. For a distance shorter than 400 mm, the limiting value was exceeded.

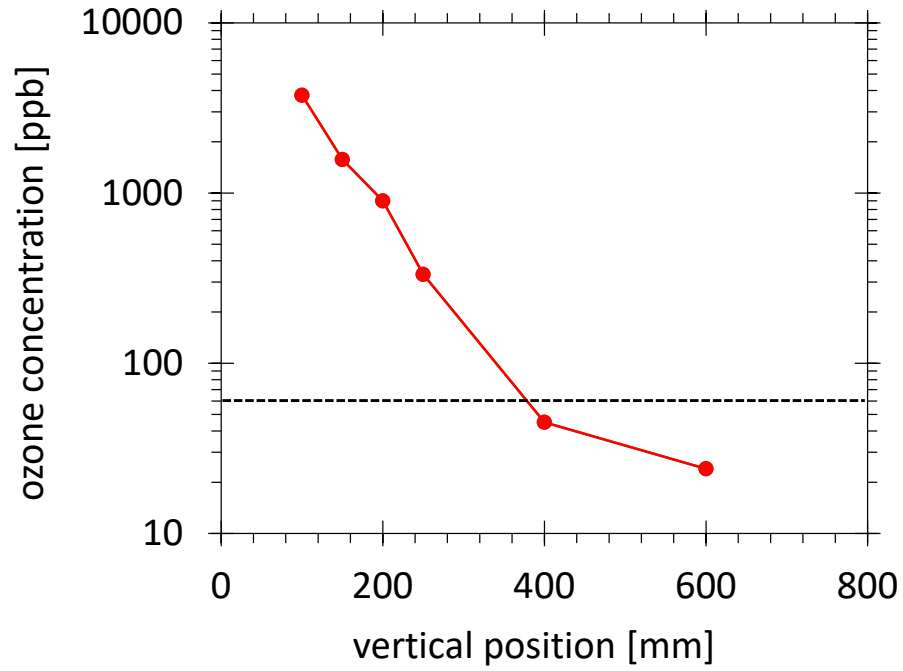

Figure 10: Mean concentration of ozone generated by piezobrush[®] PZ3 operated with full power (8 W) as a function of vertical distance between the sensor suction terminal and the piezobrush[®] PZ3, at a vertical distance of 250 mm.

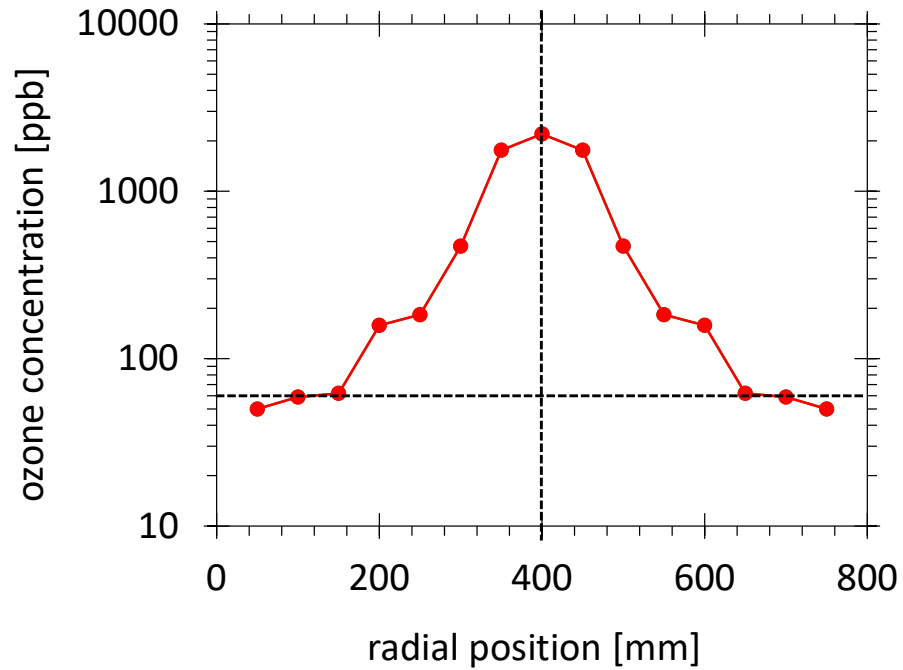

Figure 11: Mean concentration of ozone generated by piezobrush[®] PZ3 operated with full power (8 W) as a function of horizontal distance between the sensor suction terminal and the piezobrush[®] PZ3, at a vertical distance of 250 mm.

6.3 Radial distribution

Figure 11 shows the radial distribution of ozone concentration in the vertical distance of $d_z = 250$ mm between the piezobrush[®] PZ3 nozzle and the ozone sensor gas inlet. It demonstrates, that within the diameter of 440 mm, the ozone concentration exceeded the limiting value of 60 ppb.

This corresponds to a situation where the operator of the piezobrush[®] PZ3 directs the instrument to his face when working on the desk. The respiratory minute volume during light activities, maybe about 12 l/min, is comparable with the airflow of piezobrush[®] PZ3. Breathing the air with a harmful concentration of ozone would be possible. To avoid such risk, the instrument should never be directed to one's own face or the face of other people.

7 Conclusion

In PDD, as in all air-based cold atmospheric discharges, the RONS are produced, which are inevitable for plasma processing. One of long-living RONS, which can be reliably measured, is ozone. In high doses, ozone is harmful to all organisms and consequently, humans. If piezobrush[®] is operated in a small, not ventilated room, within few minutes a harmful concentration of ozone is obtained. As limiting value for long-term exposition to ozone the ozone concentration of 60 ppb can be considered, however currently no official regulatory value is set in European Union. To avoid the ozone hazard for the operator of the PCPGs, gas extraction and good ventilation are needed. To assure the efficiency of gas extraction, the funnel of the extraction system should be as close to piezobrush[®] PZ3 as possible. For a short distance between the suction funnel and the piezobrush[®] a small suction power is sufficient to keep the ozone concentration low. If this distance increases, much stronger gas extraction power is needed. The ozone distribution in space has a directional character, with the highest concentration along the axis. This is why breathing the air directly in front of the piezobrush[®], should be avoided.

References

- [1] BATAKLIEV, T., GEORGIEV, V., ANACHKOV, M., RAKOVSKY, S., AND ZAIKOV, G. Ozone decomposition. *Interdiscip Toxicol.* 7, 2 (2014), 47–59.
- [2] BENSON, S. W., AND AXWORTHY, A. E. Mechanism of the gas phase, thermal decomposition of ozone. *The Journal of Chemical Physics* 26, 6 (1957), 1718–1726.
- [3] BUNTAT, Z. *Ozone generation using electrical discharges*. VDM Verlag Dr. Müller, Dudweiler Landstr. 99, 66123 Saarbrücken, Germany, 2010, ch. 1.7.1, p. 14.
- [4] BUNTAT, Z., SMITH, I. R., AND RAZALI, N. A. M. Ozone generation by pulsed streamer discharge in air. *Applied Physics Research* 1, 2 (2009), 2–10.
- [5] CHANG, J. S., LAWLESS, P. A., AND YAMAMOTO, T. Corona discharge processes. *IEEE Transactions on Plasma Science* 19, 6 (Dec 1991), 1152–1166.
- [6] CHRISTENSEN, P. A., YONAR, T., AND ZAKARIA, K. The electrochemical generation of ozone: A review. *Ozone: Science & Engineering* 35, 3 (2013), 149–167.
- [7] CUONG, D. M. *Piezoelectric Transformer Integration Possibility in High Power Density Applications*. Verlag der Wissenschaften GmbH, Bergstr. 70, D-01069 Dresden, 2008.
- [8] DHANDAPANI, B., AND OYAMA, S. Gas phase ozone decomposition catalysts. *Applied Catalysis B: Environmental* 11 (1997), 129–166.
- [9] DOHAN, J., AND MASSCHELEIN, W. The photochemical generation of ozone: Present state-of-the-art. *Ozone: Science & Engineering* 9, 4 (1987), 315–334.
- [10] DRÄGER. *Dräger-Tubes-/CMS-Handbook*, 14th ed. Dräger Safety AG & Co KGaA, Revalstrasse 1, 23560 Luebeck, Germany, 2005.
- [11] ELIASSON, B., HIRTH, M., AND KOGELSCHATZ, U. Ozone synthesis from oxygen in dielectric barrier discharges. *J. Phys. D: Appl. Phys.* 20 (1987), 1421–37.
- [12] ELIASSON, B., AND KOGELSCHATZ, U. Ozone generation with narrow-band UV radiation. *Ozone: Science & Engineering* 13, 3 (1991), 365–373.
- [13] FRIDMAN, A. *Plasma Chemistry*. Cambridge University Press, New York, 2008, pp. 389–390.

- [14] FRIDMAN, A. *Plasma Chemistry*. Cambridge University Press, New York, 2008, pp. 387–388.
- [15] GARDONI, D., VAILATI, A., AND CANZIANI, R. Decay of ozone in water: A review. *Ozone: Science & Engineering* 34 (2012), 233–242.
- [16] ITOH, H. Discharge plasmas generated by piezoelectric transformer and their applications. In *Proc. 27th ICPIG, July 18-22* (Eindhoven, the Netherlands, 2005), pp. 1–4.
- [17] ITOH, H., TERANISHI, K., AND SUZUKI, S. Discharge plasmas generated by piezoelectric transformers and their applications. *Plasma Sources Sci. Technol.* 15, 2 (2006), S51.
- [18] KALLAEV, S. N., GADZHIEV, G. G., KAMILOV, I. K., OMAROV, Z. M., SADYKOV, S. A., AND REZNICHENKO, L. A. Thermal properties of pzt-based ferroelectric ceramics. *Physics of the Solid State* 48, 6 (2006), 1169–1170.
- [19] KOGELSCHATZ, U., ELIASSON, B., AND HIRTH, M. Ozone generation from oxygen and air: Discharge physics and reaction mechanisms. *Ozone Science & Engineering* 10 (1988), 367–378.
- [20] LANG, S. B., LASHLEY, J. C., MODIC, K. A., FISHER, R. A., ZHU, W. M., AND YE, Z. G. Specific heat of a ferroelectric pzt ceramic at the morphotropic phase boundary. *10th IEEE International Conference on Solid Dielectrics* (2010), 1–3.
- [21] LE, Q., KESTERS, E., PRAGER, L., CLAES, M., LUX, M., AND VEREECKE, G. Modification of photoresist by UV for post-etch wet strip applications. *Solid State Phenomena 145-146* (2009), 323–326.
- [22] MASUDA, S., AKUTSU, K., KURODA, M., AWATSU, Y., AND SHIBUYA, Y. A ceramic-based ozonizer using high-frequency discharge. *IEEE Tr. on Industry Applications* 24, 2 (1988), 223–231.
- [23] MATSUMI, Y., AND KAWASAKI, M. Photolysis of atmospheric ozone in the ultraviolet region. *Chemical Reviews* 103, 12 (2003), 4767–4782. PMID: 14664632.
- [24] MCCLURKIN, J., AND MAIER, D. Half-life time of ozone as a function of air conditions and movement. In *10th International Working Conference on Stored Product Protection*. Julius-Kühn-Archiv, Estoril, Portugal, 27 June–2 July, 2010, pp. 381–385.

- [25] RADHAKRISHNAN, R. *Structure and Ozone Decomposition Reactivity of Supported Manganese Oxide Catalysts*. PhD thesis, Virginia Polytechnic Institute and State University, USA, Blacksburg, Virginia, USA, 2001.
- [26] RAZUMOVSKY, S., GORSHENEV, V., KOVARSKII, A., AND SHCHEGOLIKHIN, A. Dynamics and mechanism of the interaction of graphite powders with ozone. *Russian Chemical Bulletin, International Edition* 57, 9 (2008), 1806–1810.
- [27] SALVERMOSER, M. J., KOGELSCHATZ, U., AND MURNICK, D. E. Influence of humidity on photochemical ozone generation with 172 nm xenon excimer lamps. *Eur. Phys. J. Appl. Phys.* 47, 22812 (2009), 1–6.
- [28] SCHÖNBEIN, C. On the odour accompanying electricity and on the probability of its dependence on the presence of a new substance. *Philos. Mag. (III)* 17 (1840), 293–294.
- [29] SHIMIZU, T., SAKIYAMA, Y., GRAVES, D. B., ZIMMERMANN, J. L., AND MORFILL, G. E. The dynamics of ozone generation and mode transition in air surface micro-discharge plasma at atmospheric pressure, 2012.
- [30] SKALNÝ, J., ORSZÁGH, J., Š. MATEJČÍK, AND MASON, N. Ozone generation in positive and negative corona discharge fed by humid oxygen and carbon dioxide. *Physica Scripta T131* (2008), 014012–1–014012–3.
- [31] SOTELO, J., BLTRÁN, F., BENÍTEZ, F., AND BLTRÁN-HEREDIA, J. Ozone decomposition in water: Kinetic study. *Ind. Eng. Chem. Rev.* 26, 26 (1987), 39–43.
- [32] TERANISHI, K., SHIMOMURA, N., SUZUKI, S., AND ITOH, H. Development of dielectric barrier discharge-type ozone generator constructed with piezoelectric transformers: effect of dielectric electrode materials on ozone generation. *Plasma Sources Sci. Technol.* 18, 4 (2009), 045011.
- [33] TERANISHI, K., SUZUKI, S., AND ITOH, H. A novel generation method of dielectric barrier discharge and ozone production using a piezoelectric transformer. *Japanese Journal of Applied Physics* 43, 9B (2004), 9733–9739.